



Green Passion

Illustrated Parts List

XK 140HD-XK 160HD-XK4 160HD
Model Year 2008

- Use GLOBAL GARDEN PRODUCT Genuine Spare Parts specified in the parts list for repair and/or replacement.
- The contents described in the parts list may change due to improvement.
- The drawings of the spare parts are only indicative and might not represent the part in question exactly.
- The indications "right" - "left" - "front" - "rear" refer to the position of the operator when using the machine.
- When placing orders of parts for repair and/or replacement, make sure that the illustrated parts list is the one applying to the machine's year of manufacture, as shown on the identification plate attached to the machine.

COPYRIGHT by GLOBAL GARDEN PRODUCTS

All rights reserved. No part of this material may be reproduced or transmitted, in any form or by any means, electronic or mechanical, including photocopying, recording or by any information storage and retrieval system, without permission in writing from GLOBAL GARDEN PRODUCTS.

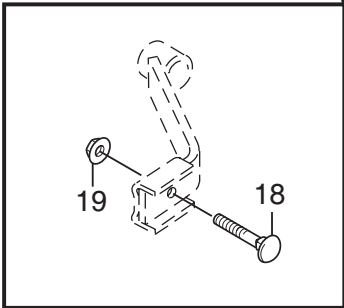
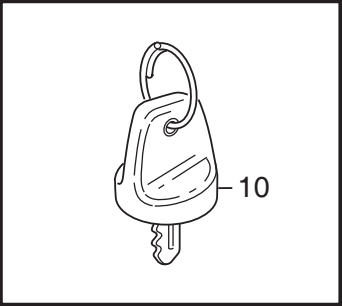
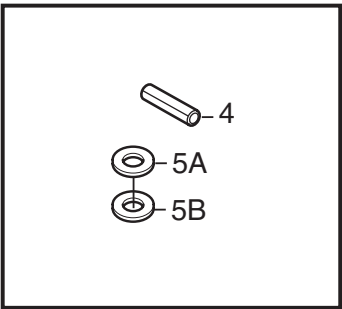
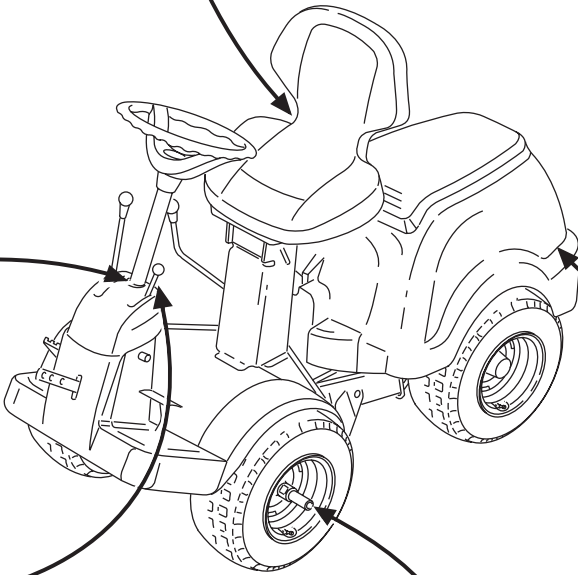
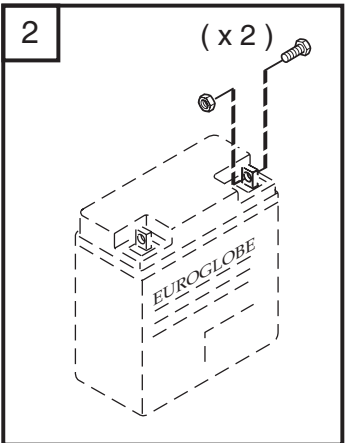
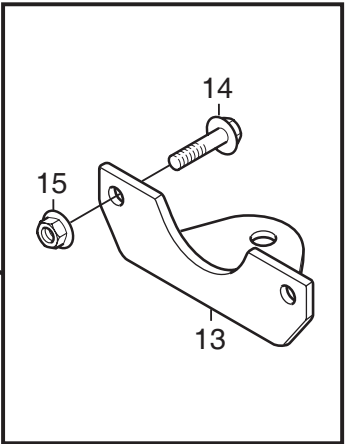
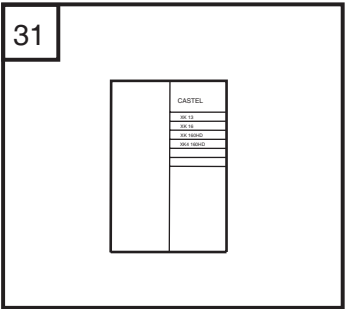
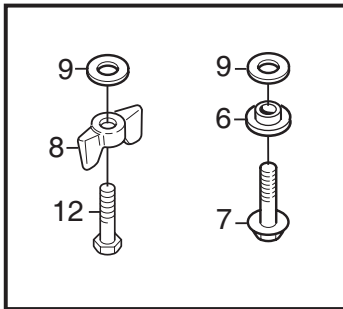

Ausgabe Issue 2008-31		Bild Nr Picture No C138		XK 140HD- XK 160HD- XK4 160HD MONTAGETEILE		XK 140HD- XK 160HD- XK4 160HD ASSEMBLY PARTS		Seite Page 76	
Pos. Fig.	Anzahl/Quantity				Artikel Nr. Part No	Bezeichnung	Description	Satz Kit	Anmerkung Notes
	6102 6103 6104 -89	6103 6104 -39							
	2	1	1		1134-6113-01	Batterieschrauben.....	Battery screws		
	4	1	1		9595-0262-00	Spannstift	Locating pin		
	5A	1	1		9699-0103-02	Scheibe.....	Flat washer.....		0.5 mm
	5B	1	1		9699-0114-02	Scheibe.....	Flat washer.....		1.0 mm
	6	2	2		1134-4185-01	Flanschscheibe	Flange washer		
	7	2	2		9959-0820-16	Schraube	Screw		
	8	2	2		1134-4481-01	Flügelmutter	Wing nut		
	9	4	4		9699-0056-02	Scheibe.....	Flat washer.....		
	10	2	2		1134-4734-01	Zündschlüssel	Ignition key		
	12	2	2		9997-0820-16	Schraube	Screw.....		
	13	1	1		1134-5512-01	Anhängerplatte	Towing plate.....		
	14	2	2		9959-0820-16	Schraube	Screw.....		
	15	2	2		9739-0831-22	Mutter	Nut		
	18	2	2		9898-1035-16	Schraube	Screw.....		
	19	2	2		9739-1031-22	Mutter	Nut		
X	31	1			8211-0066-81	Bedienungsanleitung	Owner's manual		
X	31	1			8211-0067-81	Bedienungsanleitung	Owner's manual		
X	31		1		8211-0083-80	Bedienungsanleitung	Owner's manual		CA
X	31	1			8211-0611-81	Montageanweisung	Assy instructions		
X	31	1			8211-0781-80	Sicherheitsvorschrift	Safety regulations		

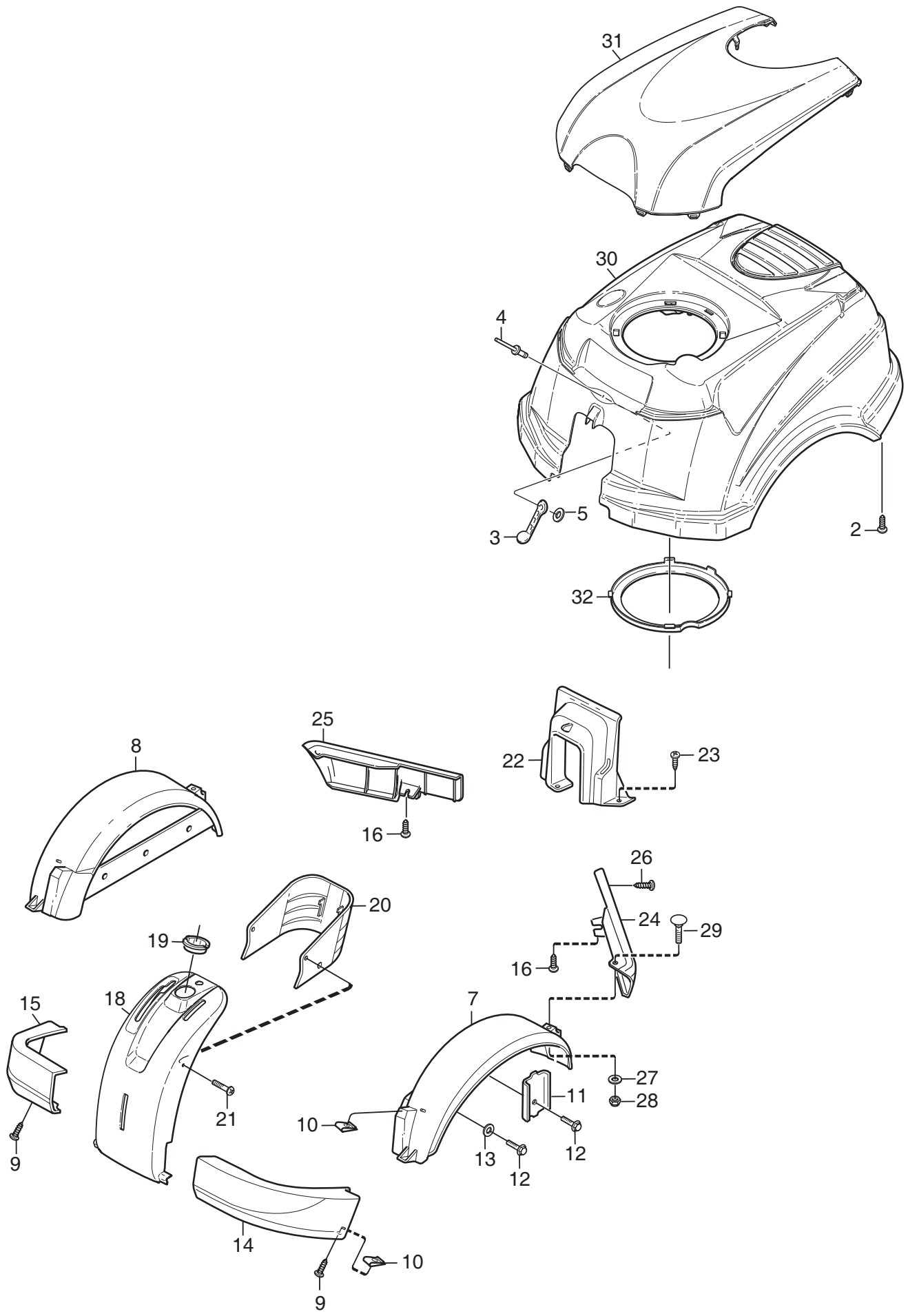

Ausgabe Issue 2008-31		Bild Nr Picture No C195		XK 140HD XK 160HD- XK4 160HD KAROSSERIE		XK 140HD- XK 160HD- XK4 160HD BODY WORK		Seite Page 78	
Pos. Fig.	Anzahl/Quantity				Artikel Nr. Part No	Bezeichnung	Description	Satz Kit	Anmerkung Notes
	6102	6103	6104						
2	7				9838-9530-12	Schraube	Screw		
3	1				1134-2143-01	Gummistropf	Rubber strap		
4	1				9632-0516-00	Niet	Pop rivet		
5	1				9699-0120-02	Scheibe	Washer		
7	1				1134-5308-06	Kotflügel L- grau	Mud guard LH- grey		
8	1				1134-5308-05	Kotflügel R- grau	Mud guard RH- grey		
9	4				9893-0616-16	Schraube	Screw		
10	4				1134-4176-01	Klemme	Clips		
11	2				1134-0225-00	Stützblech	Support plate		
12	6				9945-0816-16	Schraube	Screw		
13	4				9699-0056-02	Scheibe	Flat washer		
14	1				1134-5367-01	Stoßfänger- vorder, L	Bumper- front, LH		
15	1				1134-5367-02	Stoßfänger- vorder, R	Bumper- front, RH		
16	2				9893-0616-16	Schraube	Screw		
18	1				1134-6748-01	Vorderpanel	Front decor		
19	1				1134-4483-01	Buchse	Bushing		
20	1				1134-5361-01	Vorderdeckel	Front cover		
21	2				9840-8019-16	Schraube	Screw		
22	1				1134-6241-01	Haubenstütz	Hood support		
23	3				9893-0616-16	Schraube	Screw		
24	1				1134-3970-10	Leiste L- grau	Moulding- LH, grey		
25	1				1134-3970-09	Leiste R, grau	Moulding- RH, grey		
26	2				9893-0616-16	Schraube	Screw		
27	2				9699-0060-02	Scheibe	Flat washer		
28	2				9747-0631-02	Mutter	Lock nut		
29	2				9897-0616-16	Schraube	Carriage bolt		
30	1				1134-5744-03	Motorhaube- rot	Engine hood- red		
31	1				1134-5743-03	Motordeckel- grau	Engine cover- grey		
32	1				1134-6116-06	Luftring	Air duct		

X

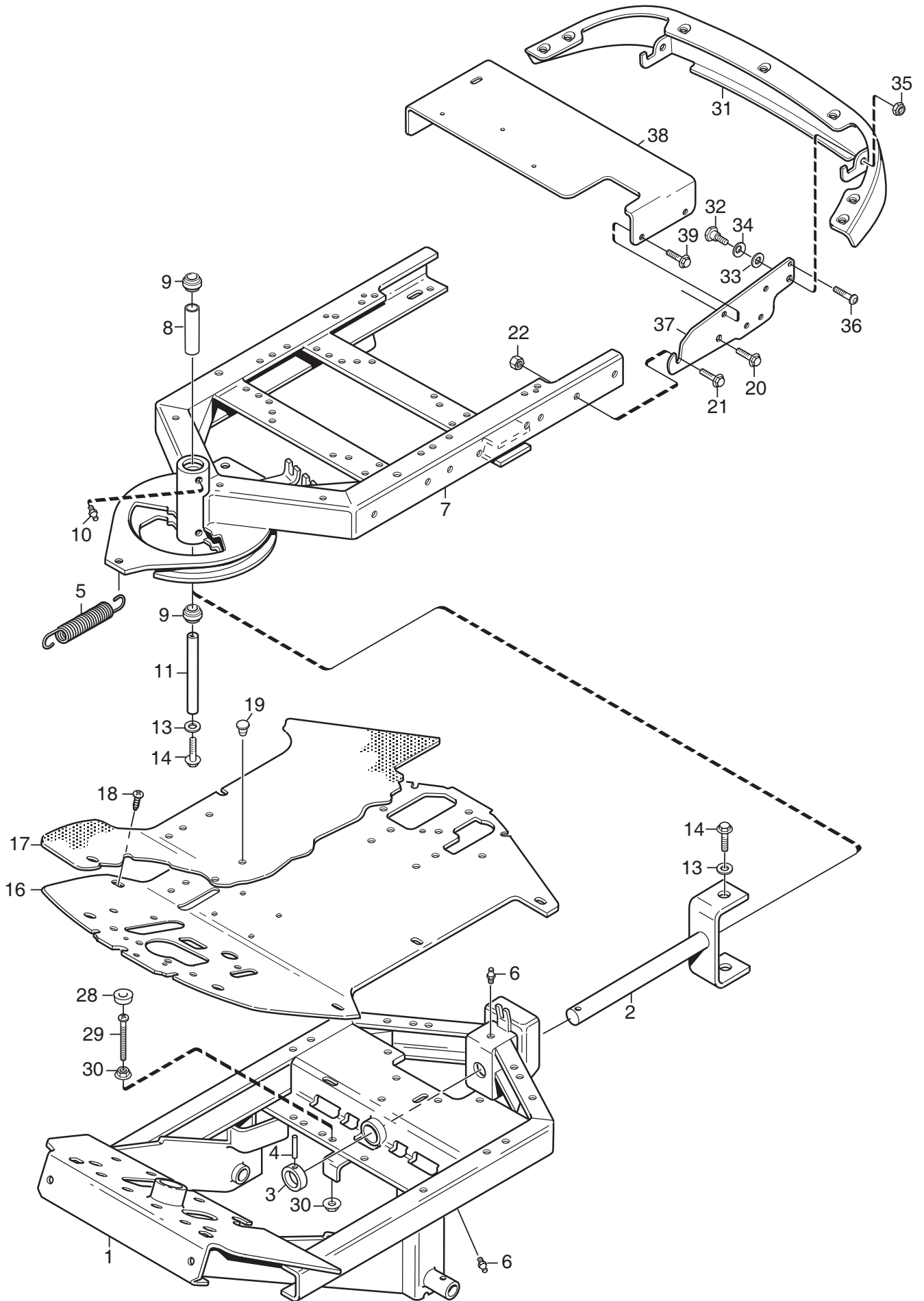

Ausgabe Issue 2008-31		Bild Nr Picture No C140		XK 140HD- XK 160HD RAHMEN 2WD		XK 140HD- XK 160HD FRAME 2WD		Seite Page 80	
Pos. Fig.	Anzahl/Quantity				Artikel Nr. Part No	Bezeichnung	Description	Satz Kit	Anmerkung Notes
	6102	6103							
X	1	1			1134-5315-03	Rahmen- vordere	Frame- front		Grey
	2	1			1134-3963-02	• Gabel	• Clevis		
	3	1			1134-0031-00	• Lenkachsenanschlag	• Pivot shaft stop		
	4	1			9595-0262-00	• Spannstift	• Locating pin		
	5	1			1134-2171-01	Feder	Spring		
	6	2			9501-0500-00	Schmiernippel	Grease joint		
	7	1			1134-6466-01	Rahmen- hintere	Frame- rear		
	8	1			1134-5705-01	• Distanz	• Spacer		
	9	2			9547-0001-00	• Lager	• Bearing		
	10	2			9501-0500-00	• Schmiernippel	• Grease joint		
	11	1			1134-5988-01	Zentrumachse	Centre shaft		
	13	2			9699-0035-02	Scheibe	Flat washer		
	14	2			9959-1025-16	Schraube	Screw		
	16	1			1134-5294-01	Bodenblech	Floor plate		
	17	1			1134-6372-04	Bodenblechmatte	Floor mat		
	18	2			9893-0616-16	Schraube	Screw		
	19	2			9403-0048-70	Propfen	Plug		
	20	2			9945-0816-16	Schraube	Screw		
	21	2			9959-0820-16	Schraube	Screw		
	22	2			9739-0831-22	Mutter	Nut		
	28	1			1134-4975-01	Gummidämpfer	Rubber block		
	29	1			9950-0570-12	Schraube	Screw		
	30	2			9739-0531-22	Mutter	Nut		
	31	1			1134-5337-03	Stoßfänger- hintere	Bumper- rear, grey		
	32	2			1134-0240-00	Ansatzbolzen	Shoulder screw		
	33	2			1134-4242-01	Distanzscheibe	Spacer washer		
	34	2			9665-0002-00	Tellerscheibe	Bowed washer		
	35	2			9747-0831-02	Mutter	Lock nut		
	36	2			9943-0516-16	Schraube	Screw		
	37	2			1134-5345-01	Halterung	Attachment		
	38	1			1134-5344-01	Batterieregal	Battery shelf		
	39	4			9945-0816-16	Schraube	Screw		

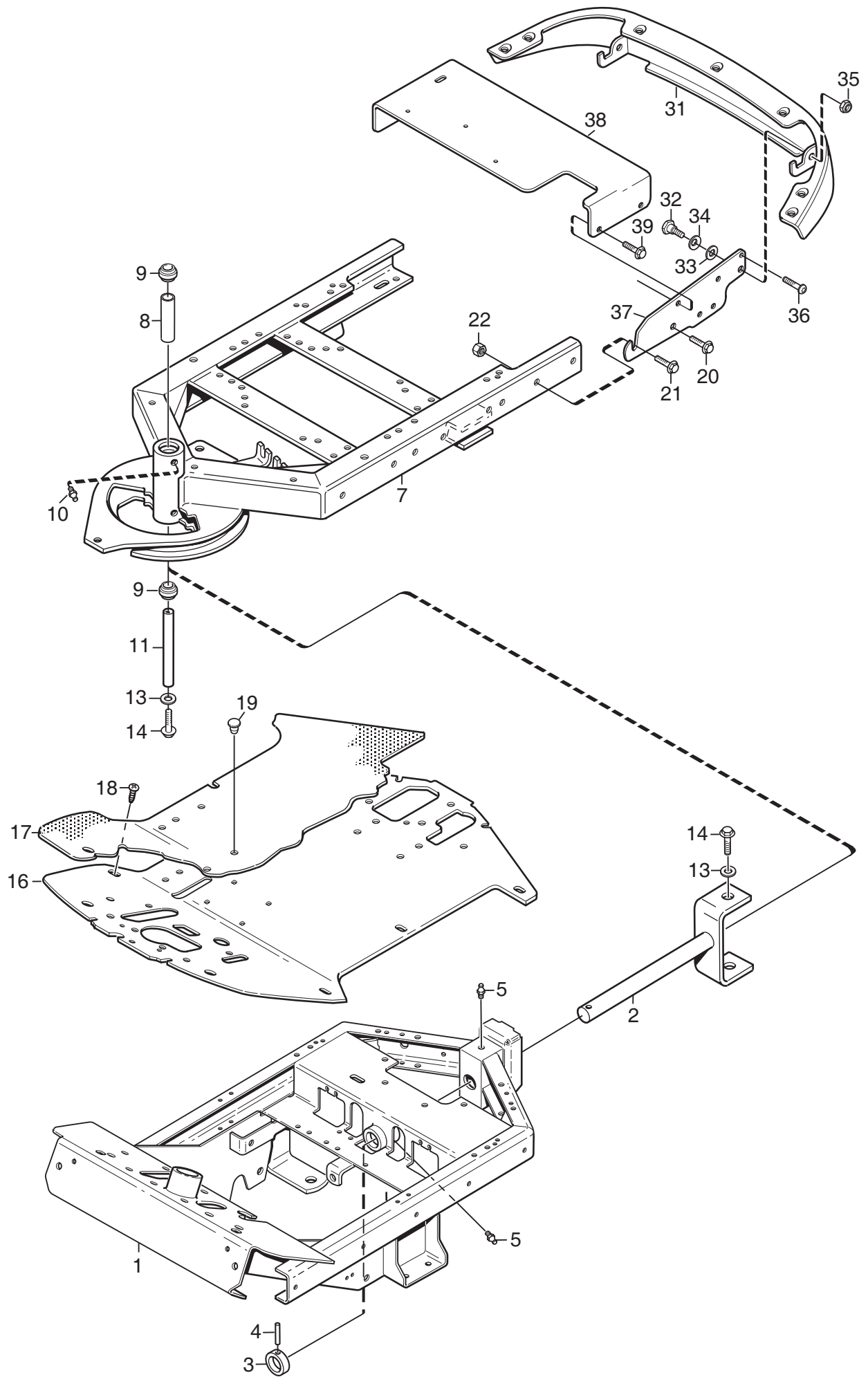

C141

Ausgabe Issue 2008-31		Bild Nr Picture No C141		XK4 160HD RAHMEN 4WD		XK4 160HD FRAME 4WD		Seite Page 82	
Pos. Fig.	Anzahl/Quantity				Artikel Nr. Part No	Bezeichnung	Description	Satz Kit	Anmerkung Notes
	6104								
1	1				1134-5656-02	Rahmen- vordere	Frame- front		
2	1				1134-3963-02	• Gabel	• Clevis		
3	1				1134-0031-00	• Lenkachsenanschlag	• Pivot shaft stop		
4	1				9595-0262-00	• Spannstift	• Locating pin		
5	2				9501-0500-00	• Schmiernippel	• Grease joint		
7	1				1134-6466-01	Rahmen- hintere	Frame- rear		
8	1				1134-5705-01	• Distanz	• Spacer		
9	2				9547-0001-00	• Lager	• Bearing		
10	2				9501-0500-00	• Schmiernippel	• Grease joint		
11	1				1134-5988-01	Zentrumachse	Centre shaft		
13	2				9699-0035-02	Scheibe	Flat washer		
14	2				9959-1025-16	Schraube	Screw		
16	1				1134-6586-01	Bodenblech	Floor plate		
17	1				1134-6372-04	Bodenblechmatte	Floor mat		
18	2				9893-0616-16	Schraube	Screw		
19	2				9403-0048-70	Propfen	Plug		
20	2				9945-0816-16	Schraube	Screw		
21	2				9959-0820-16	Schraube	Screw		
22	2				9739-0831-22	Mutter	Nut		
31	1				1134-5337-03	Stoßfänger- hintere	Bumper- rear, grey		Grey
32	2				1134-0240-00	Ansatzbolzen	Shoulder screw		
33	2				1134-4242-01	Distanzscheibe	Spacer washer		
34	2				9665-0002-00	Tellerscheibe	Bowed washer		
35	2				9747-0831-02	Mutter	Lock nut		
36	2				9943-0516-16	Schraube	Screw		
37	2				1134-5345-01	Halterung	Attachment		
38	1				1134-5344-01	Batterieregal	Battery shelf		
39	4				9945-0816-16	Schraube	Screw		

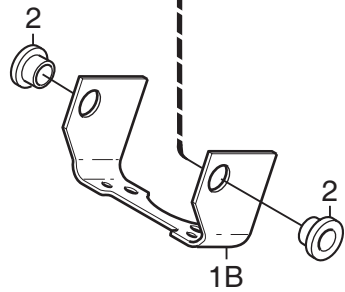
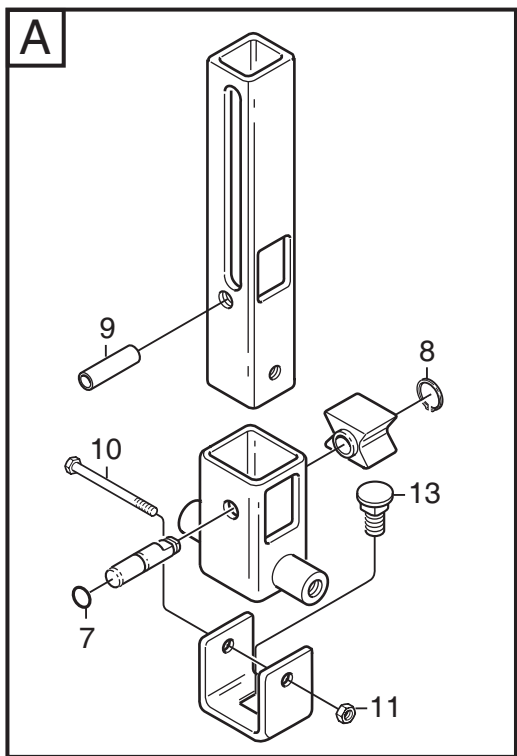
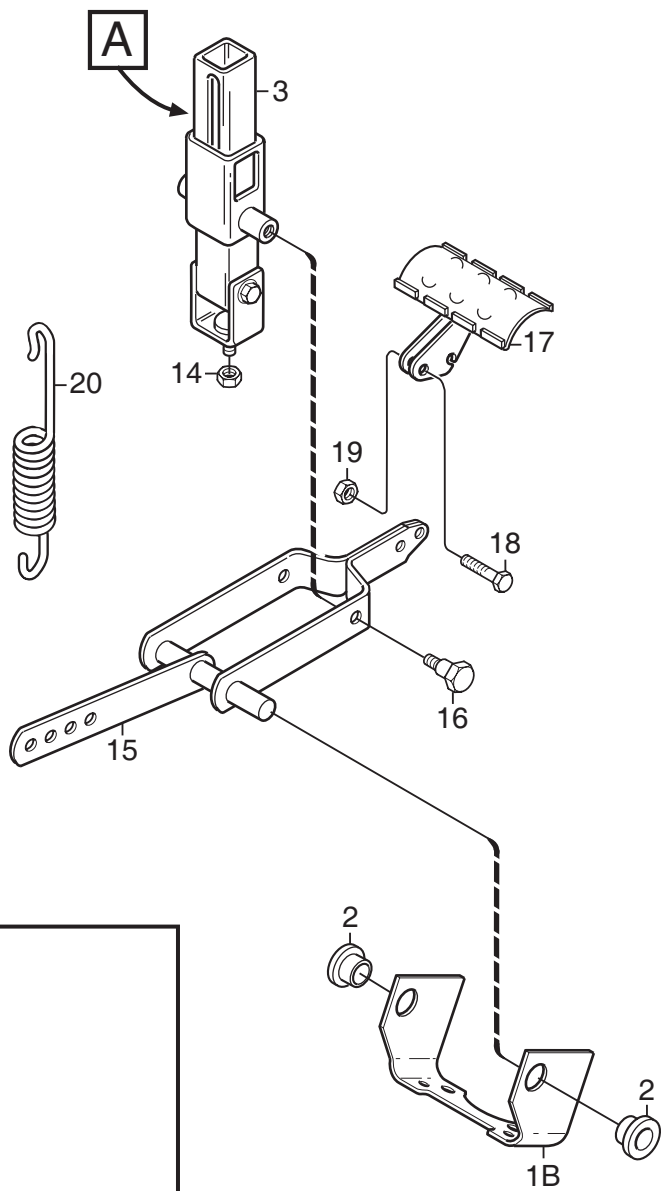

Ausgabe Issue 2008-31		Bild Nr Picture No C142A		XK 140HD XK 160HD- XK4 160HD PEDALHEBER		XK 140HD- XK 160HD- XK4 160HD PEDAL LIFT		Seite Page 84	
Pos. Fig.	Anzahl/Quantity				Artikel Nr. Part No	Bezeichnung	Description	Satz Kit	Anmerkung Notes
	6102	6103	6104						
1B	1				1134-4117-01	Halterung.....	Bracket.....		
2	2				1134-2684-01	Lager.....	Bearing.....		
3	1				1134-4945-01	Hebesperre Kpl.....	Lift catch assy.....		
7	1				9404-0027-01	• O- ring.....	• O- ring.....		
8	1				9650-0039-04	• Schließring.....	• Lock ring.....		
9	1				9595-0276-01	• Spannstift.....	• Locating pin.....		
10	1				9997-0640-12	• Schraube.....	• Screw.....		
11	1				9747-0631-02	• Mutter.....	• Lock nut.....		
13	1				9897-0820-16	• Schraube.....	• Screw.....		
14	1				9747-0831-02	Mutter.....	Lock nut.....		
15	1				1134-4860-01	Hebegabel.....	Lift fork.....		
16	2				1134-0240-00	Ansatzbolzen.....	Shoulder screw.....		
17	1				1134-4938-01	Hebepedal.....	Lift pedal.....		
18	2				9997-0625-16	Schraube.....	Screw.....		
19	2				9739-0631-22	Mutter.....	Nut.....		
20	1				4231-0013-00	Feder.....	Spring.....		

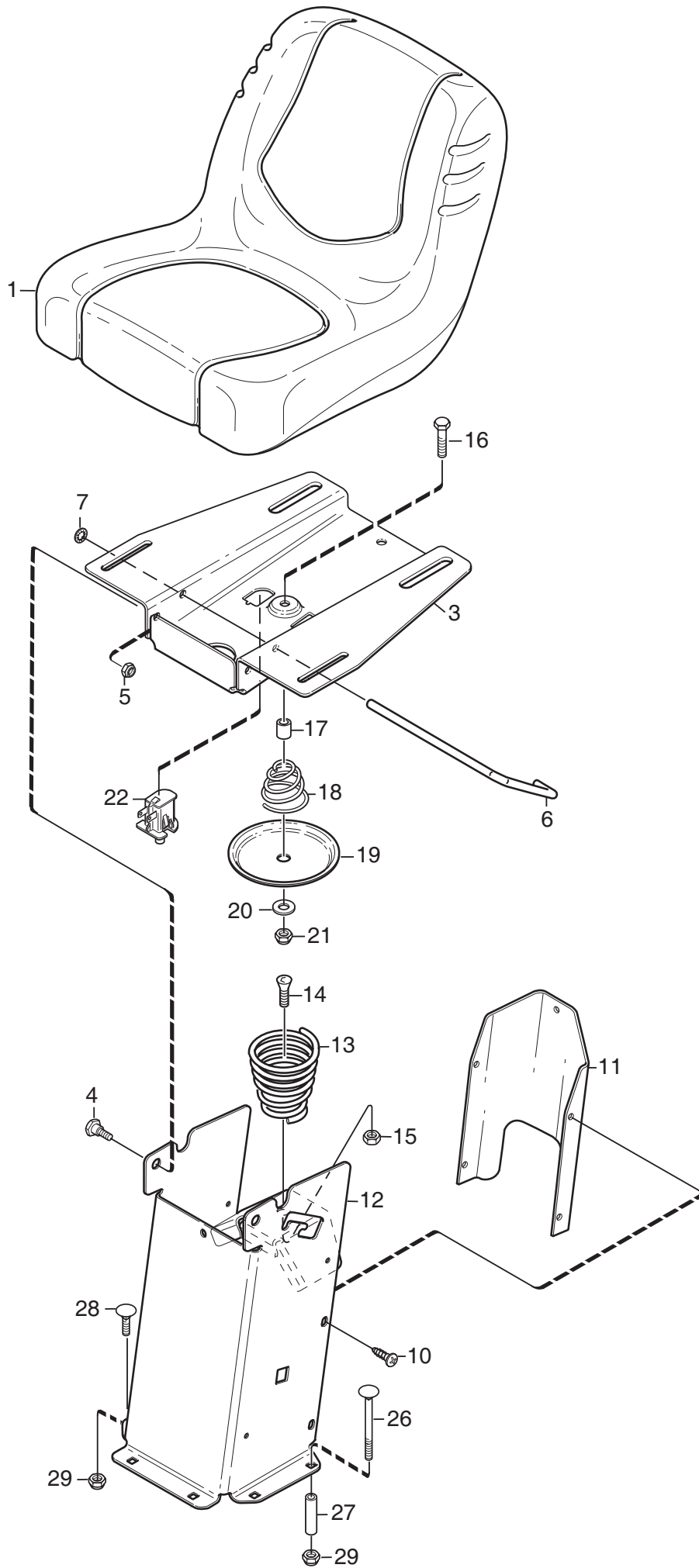

Ausgabe Issue 2008-31		Bild Nr Picture No C143		XK 140HD- XK 160HD- XK4 160HD SITZ		XK 140HD- XK 160HD- XK4 160HD SEAT		Seite Page 86	
Pos. Fig.	Anzahl/Quantity				Artikel Nr. Part No	Bezeichnung	Description	Satz Kit	Anmerkung Notes
	6102	6103	6104						
1	1				1134-5534-01	Sitz	Seat		
3	1				1134-5301-01	Sitzplatte	Seat plate		
4	2				1134-0240-00	Ansatzbolzen	Shoulder screw		
5	2				9747-0831-02	Mutter	Lock nut		
6	1				1134-5454-01	Sperre	Catch		
7	1				9675-0012-02	Verriegelungsscheibe	Locking washer		
10	4				9893-0616-16	Schraube	Screw		
11	1				1134-5300-02	Hinterplatte- rot	Rear plate- red		
12	1				1134-5296-06	Sitzkonsole- rot	Seat bracket- red		
13	1				1134-4256-01	Sitzfeder	Seat spring		
14	1				9924-1235-19	Schraube	Screw		
15	1				9747-1231-02	Mutter	Lock nut		
16	1				9997-0840-16	Schraube	Screw		
17	1				1134-1565-06	Distanz	Spacer		
18	1				1134-5302-01	Feder	Spring		
19	1				1134-5299-01	Druckplatte	Push plate		
20	1				9699-0090-02	Scheibe	Flat washer		
21	1				9747-0831-02	Mutter	Lock nut		
22	1				1134-3156-02	Schalter (grau)	Switch (grey)		
26	2				9897-0880-12	Schraube	Screw		L = 80 mm
27	2				1134-1565-08	Distanz	Spacer		
28	4				9897-0820-16	Schraube	Screw		L = 20 mm
29	6				9747-0831-02	Mutter	Lock nut		

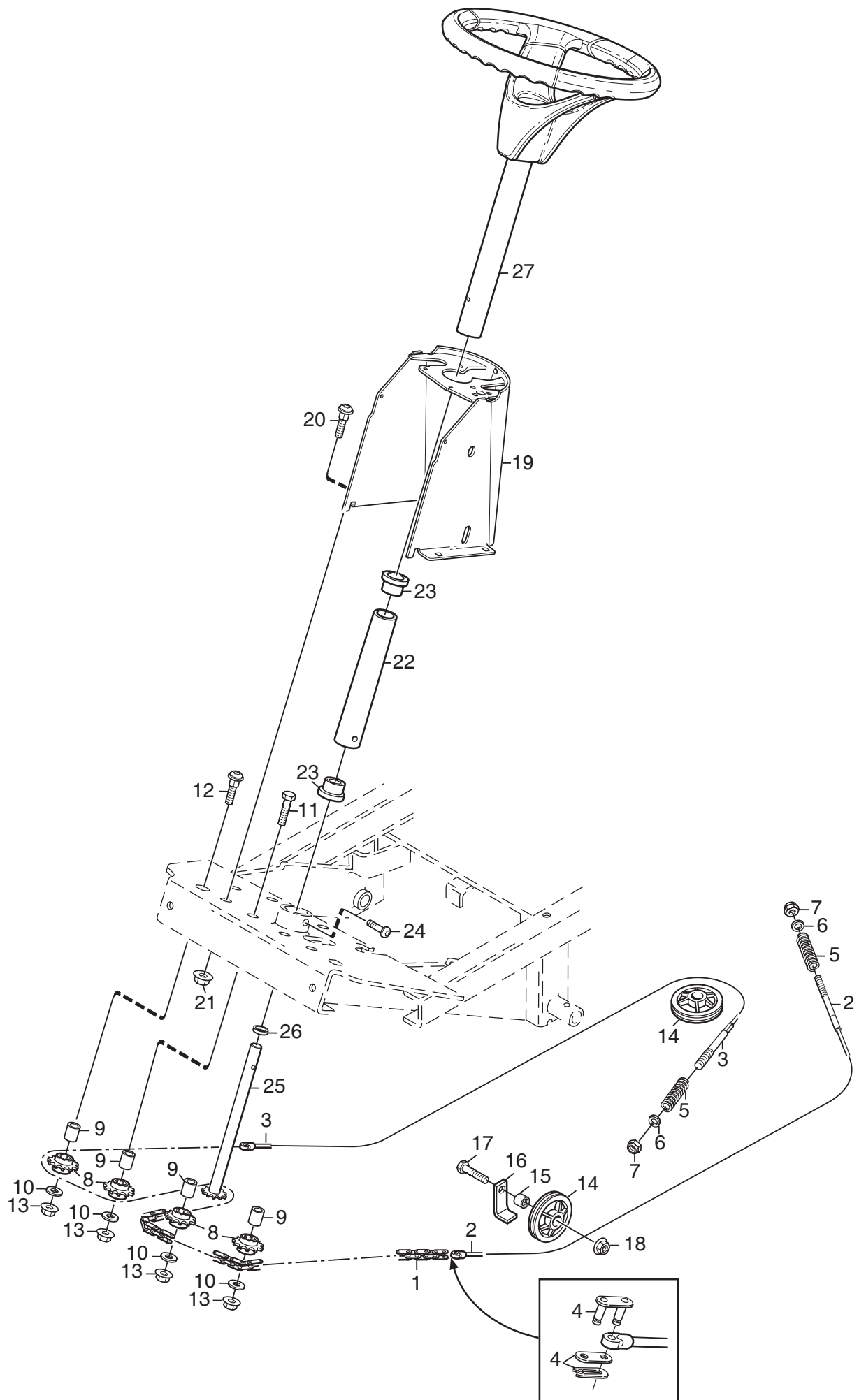

Ausgabe Issue 2008-31		Bild Nr Picture No C144		XK 140HD- XK160HD LENKUNG 2WD		XK 140HD- XK 160HD STEERING 2WD		Seite Page 88	
Pos. Fig.	Anzahl/Quantity				Artikel Nr. Part No	Bezeichnung	Description	Satz Kit	Anmerkung Notes
	6102 6103								
1	1				1134-6374-06 Kette	Chain.....		83 links	
2	1				1134-2817-01 Lenkseil- L	Steering cable- LH.....			
3	1				1134-2817-02 Lenkseil- R.....	Steering cable- RH.....			
4	2				1134-2824-02 Kettenschloß.....	Chain lock			
5	2				1134-3817-01 Druckfeder.....	Compression spring.....			
6	2				9699-0090-02 Scheibe.....	Flat washer.....			
7	2				9747-0831-02 Mutter.....	Lock nut			
8	4				1134-2816-01 Kettenrad	Sprocket.....			
9	4				1134-0041-02 Hülse	Idler wheel bush.....			
10	4				9699-0035-02 Scheibe.....	Flat washer.....			
11	2				9997-1050-16 Schraube	Screw			
12	2				9897-1040-12 Schraube	Screw			
13	4				9739-1031-22 Mutter	Nut			
X 14	3				1134-0072-02 Seilrolle	Steering pulley			
15	2				1134-0041-01 Hülse	Bushing.....			
X 16	2				1134-0046-00 Drahthalter.....	Wire clamp.....			
17	2				9997-1030-16 Schraube	Screw			
18	2				9739-1031-22 Mutter	Nut			
19	1				1134-5349-05 Lenkkonsole- grau	Steering console- grey			
20	4				9897-0820-16 Schraube	Screw			
21	4				9739-0831-22 Mutter	Nut			
22	1				1134-1305-05 Lenkrohr- untere	Steering column- lower			
23	2				1134-1901-01 Lager	Bearing.....			
24	2				9893-0616-16 Schraube	Screw			
25	1				1134-2821-03 Lenkstange	Steering rod			
26	1				1134-2837-01 Distanz.....	Spacer			
27	1				1134-5496-01 Lenkrad	Steering wheel			

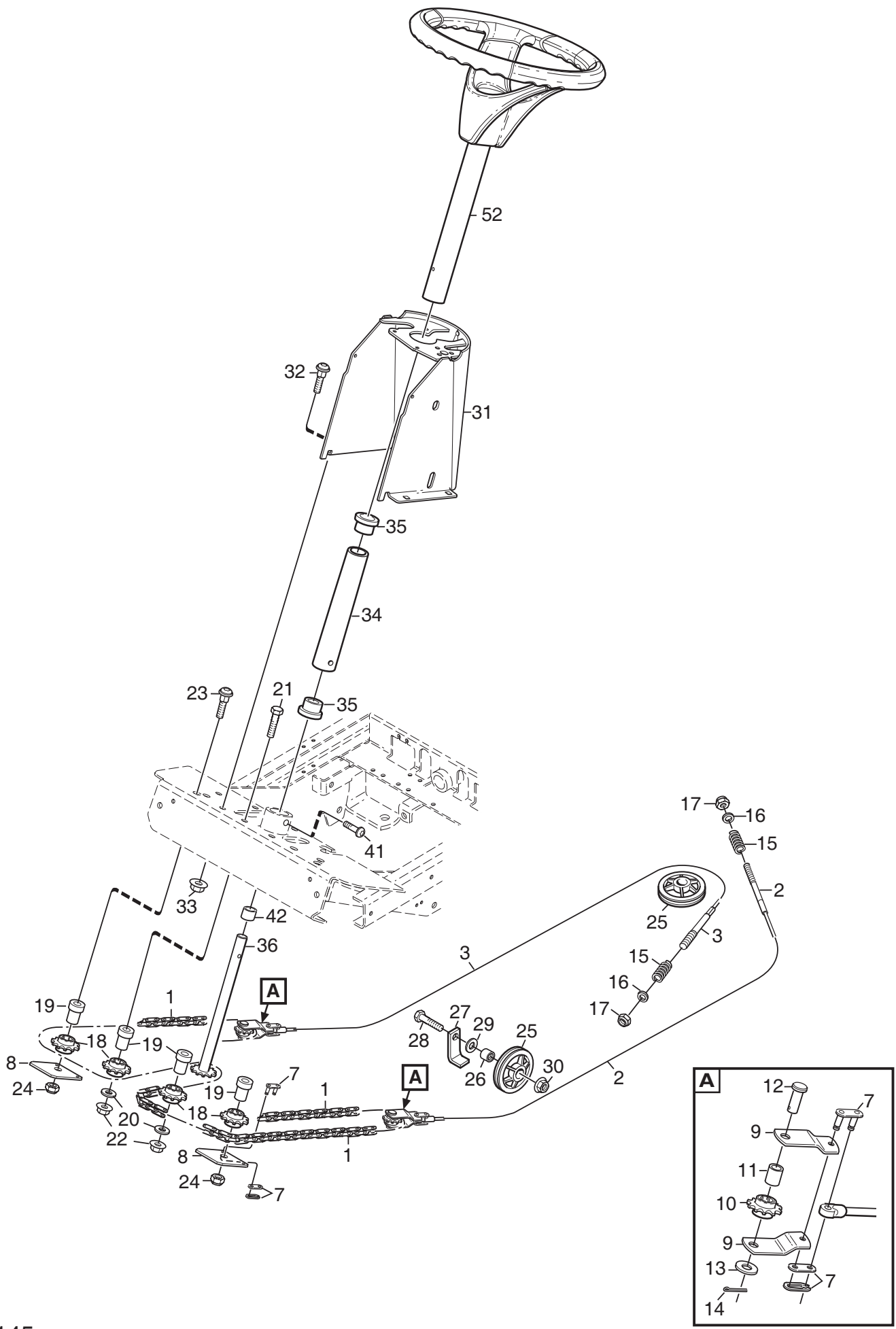

Ausgabe Issue 2008-31		Bild Nr Picture No C145		XK4 160HD LENKUNG 4WD		XK4 160HD STEERING 4WD		Seite Page 90	
Pos. Fig.	Anzahl/Quantity				Artikel Nr. Part No	Bezeichnung	Description	Satz Kit	Anmerkung Notes
	6104								
1	1				1134-6374-10 Kette	Chain.....		129 links	
2	1				1134-2817-03 Lenkseil- L	Steering cable- LH.....			
3	1				1134-2817-04 Lenkseil- R	Steering cable- RH			
7	4				1134-2824-02 Kettenschloß.....	Chain lock			
8	2				1134-5652-01 Halter	Attachment.....			
9	4				1134-5651-01 Bügel	Bracket.....			
10	2				1134-2816-01 Kettenrad	Sprocket.....			
11	2				1134-0041-02 Hülse	Idler wheel bush.....			
12	2				1134-4817-01 Zapfen	Pin			
13	2				9699-0035-02 Scheibe.....	Flat washer.....			
14	2				9599-0054-02 Splint	Cotter pin			
15	2				1134-3817-01 Druckfeder.....	Compression spring.....			
16	2				9699-0090-02 Scheibe.....	Flat washer.....			
17	2				9747-0831-02 Mutter	Lock nut			
18	4				1134-2816-01 Kettenrad	Sprocket.....			
19	4				1134-5653-01 Distanz.....	Spacer			
20	2				9699-0035-02 Scheibe.....	Flat washer.....			
21	2				9997-1060-12 Schraube	Screw.....			
22	2				9739-1031-22 Mutter	Nut			
23	2				9897-1060-12 Schraube	Screw.....			
24	2				9731-1031-22 Mutter	Nut			
X 25	3				1134-0072-02 Seilrolle	Steering pulley			
X 26	2				1134-0041-01 Hülse	Bushing.....			
27	2				1134-0046-00 Drahthalter.....	Wire clamp.....			
28	2				9997-1040-16 Schraube	Screw.....			
29	2				9699-0035-02 Scheibe.....	Flat washer.....			
30	2				9739-1031-22 Mutter	Nut			
31	1				1134-5349-05 Lenkkonsole- grau	Steering console- grey			
32	4				9897-0820-16 Schraube	Screw.....			
33	4				9739-0831-22 Mutter	Nut			
34	1				1134-1305-05 Lenkrohr- untere	Steering column- lower			
35	2				1134-1901-01 Lager	Bearing.....			
36	1				1134-2821-05 Lenkstange	Steering rod			
41	2				9893-0616-16 Schraube	Screw.....			
42	1				1134-2837-03 Distanz.....	Spacer.....			
52	1				1134-5496-01 Lenkrad	Steering wheel			

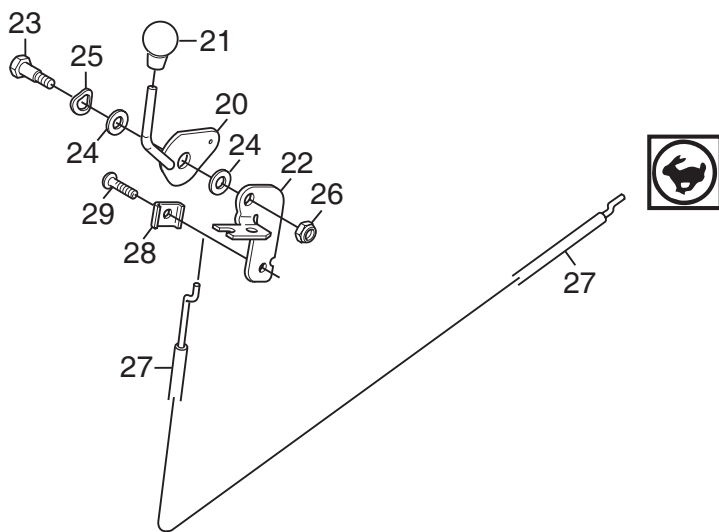
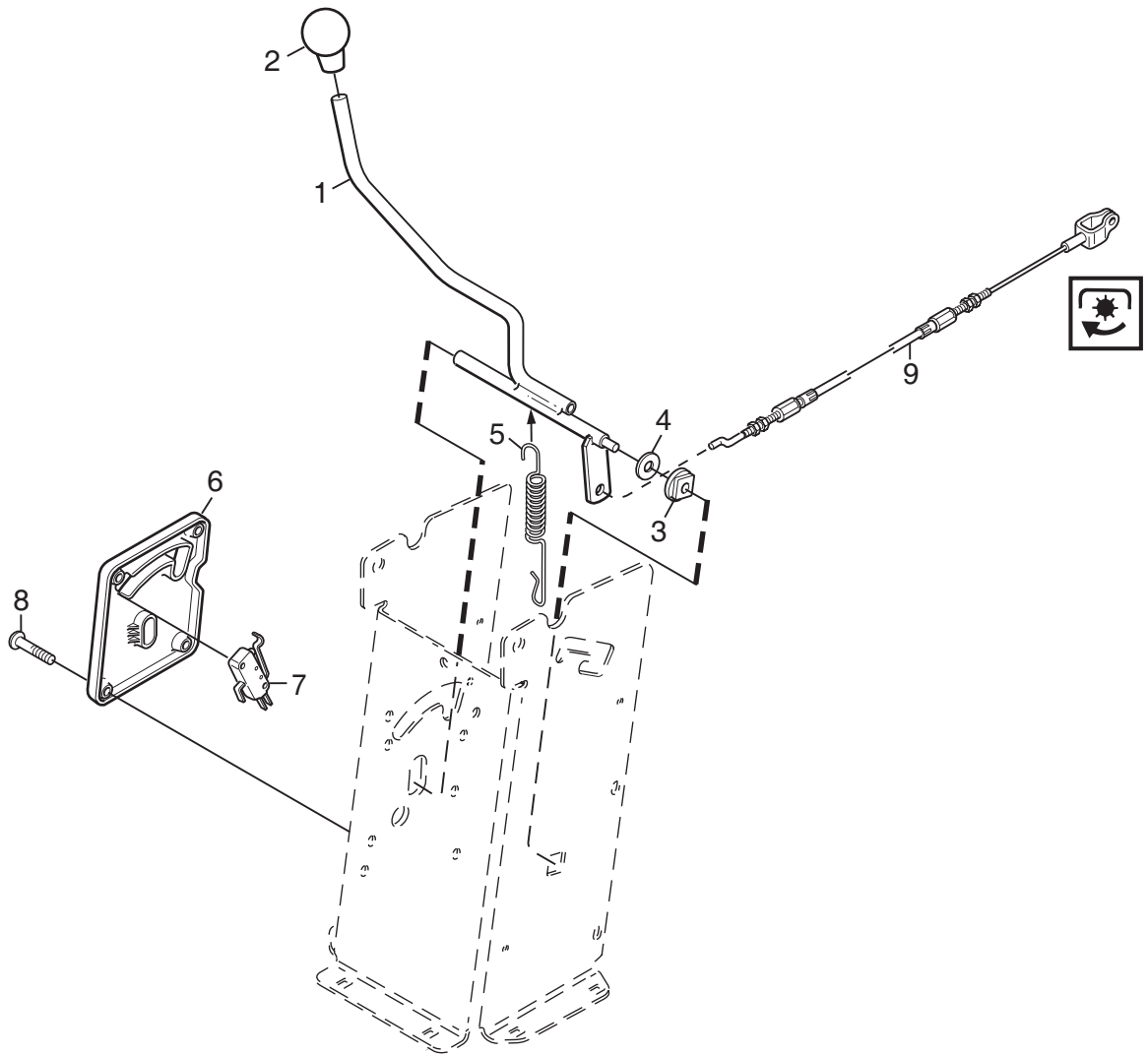

C146A

Ausgabe Issue 2008-31		Bild Nr Picture No C146A		XK 140HD- XK 160HD- XK4 160HD HANDREGULIERUNG		XK 140HD- XK 160HD- XK4 160HD HAND CONTROLS		Seite Page 92	
Pos. Fig.	Anzahl/Quantity				Artikel Nr. Part No	Bezeichnung	Description	Satz Kit	Anmerkung Notes
	6102	6103	6104						
1	1				1134-6301-01	Einkupplungshebel	Engagement lever		
2	1				1134-2551-01	Knopf	Knob		
3	1				1134-3790-02	Lager	Bearing		
4	1				9699-0090-02	Scheibe	Flat washer		
5	1				4231-0013-00	Feder	Spring		
6	1				1134-5368-01	Panel	Dashboard		
7	1				9400-0312-01	Schalter	Micro switch		
8	4				9946-0525-16	Schraube	Screw		
9	1				1134-3573-05	Regulierdraht	Control cable		
20	1				1134-5465-01	Gasregulierung	Throttle lever		
21	1				1134-4078-01	Knopf	Knob		
22	1				1134-5464-01	Halterung	Bracket		
23	1				1134-0240-00	Ansatzbolzen	Shoulder screw		
24	2				1134-4242-01	Distanzscheibe	Spacer washer		
25	1				9694-0001-00	Scheibe	Washer		
26	1				9747-0831-02	Mutter	Lock nut		
27	1				1134-4197-03	Gasdraht	Throttle cable		
28	1				9500-9991-00	Drahtklemme	Cable clamp		
29	1				9943-0516-16	Schraube	Screw		

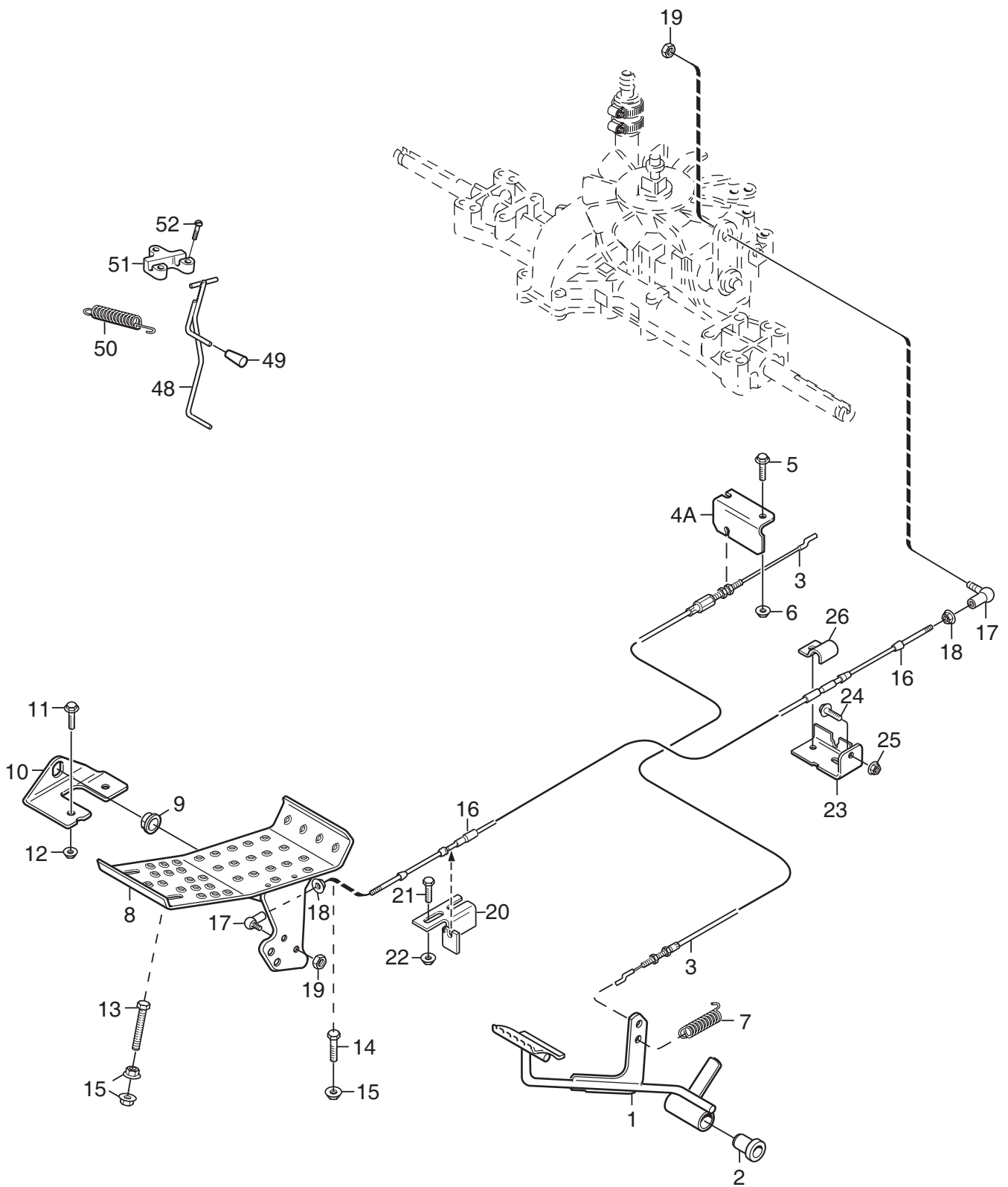

Ausgabe Issue 2008-31		Bild Nr Picture No C148		XK 140HD- XK 160HD FUßBEDIENELEMENTE 2WD		XK 140HD- XK 160HD FOOT CONTROLS 2WD		Seite Page 94	
Pos. Fig.	Anzahl/Quantity				Artikel Nr. Part No	Bezeichnung	Description	Satz Kit	Anmerkung Notes
	6102 6103								
X	1	1			1134-4247-01	Brems/Kupplungspedal	Brake/clutch pedal.....		
	2	2			1134-0068-00	• Lager	• Bearing		
	3	1			1134-3584-03	Brems/Kupplungsdraht.....	Brake/clutch cable		
	4A	1			1134-6467-01	Drahhalter.....	Cable holder		
	5	2			9959-0820-16	Schraube	Screw		
	6	2			9739-0831-22	Mutter	Nut		
	7	1			1134-3974-01	Feder	Spring		
	8	1			1134-6353-01	Fahrpedal.....	Drive pedal		
	9	2			1134-6313-01	Lager	Bearing.....		
	10	2			1134-2700-01	Halter.....	Bracket.....		
	11	2			9959-0820-16	Schraube	Screw.....		
	12	2			9739-0831-22	Mutter	Nut		
	13	1			9997-0870-16	Schraube	Screw.....		
	14	1			9959-0820-16	Schraube	Screw.....		
	15	3			9739-0831-22	Mutter	Nut		
	16	1			1134-2766-05	Fahrtregulierdraht.....	Speed control cable		
	17	2			9570-0001-00	Winkelgelenk	Elbow link		
	18	2			9739-0531-22	Mutter	Nut		
	19	2			9747-0531-02	Mutter	Nut		
	20	1			1134-6317-01	Drahhalter.....	Cable holder		
	21	2			9959-0620-16	Schraube	Screw.....		
	22	2			9739-0631-22	Mutter	Nut		
	23	1			1134-3395-01	Halterung.....	Attachment.....		
	24	2			9959-0820-16	Schraube	Screw.....		
	25	2			9739-0831-22	Mutter	Nut		
	26	1			1134-2021-01	Klemme	Clamp.....		
	48	1			1134-5353-01	Bremsstange	Brake rod		
	49	1			1134-2786-01	Plastikknopf.....	Plastic knob		
	50	1			1131-1497-01	Feder	Spring		
	51	1			1134-4002-01	Halterung.....	Brake rod attachment.....		
	52	3			9838-9516-12	Schraube	Screw		

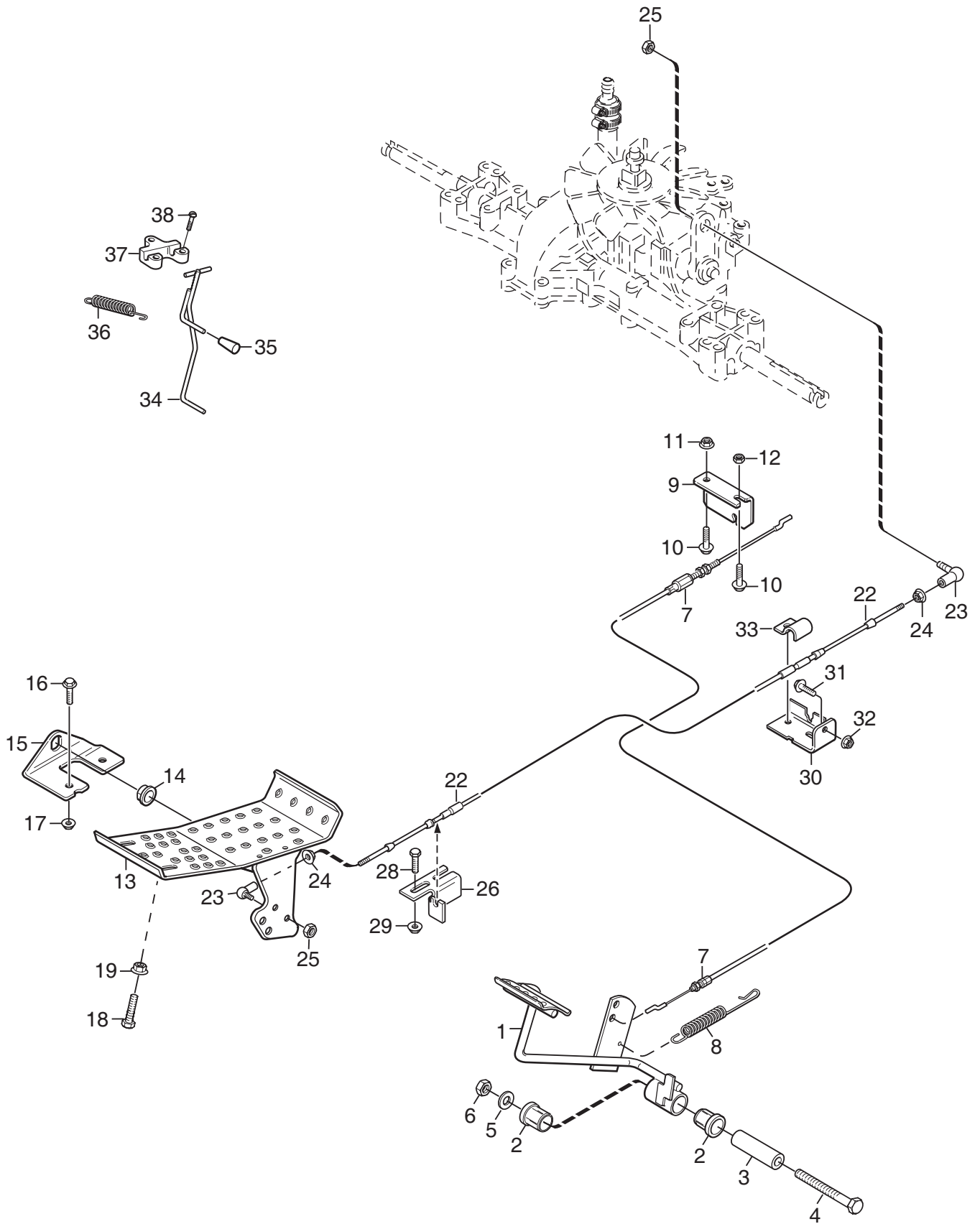

Ausgabe Issue 2008-31		Bild Nr Picture No C149		XK4 160HD FUßBEDIENELEMENTE 4WD		XK4 160HD FOOT CONTROLS 4WD		Seite Page 96	
Pos. Fig.	Anzahl/Quantity				Artikel Nr. Part No	Bezeichnung	Description	Satz Kit	Anmerkung Notes
	6104								
1	1				1134-5655-01	Brems/Kupplungspedal	Brake/clutch pedal.....		
2	2				1134-0068-00	Lager	Bearing.....		
3	1				1134-5677-02	Distanz	Spacer.....		
4	1				9997-1070-12	Schraube	Screw.....		
5	1				9699-0030-02	Scheibe.....	Flat washer.....		
6	1				9739-1031-22	Mutter	Nut.....		
7	1				1134-6005-01	Draht	Cable.....		
8	1				4231-0013-00	Feder	Spring.....		
9	1				1134-6467-01	Drahthalter.....	Cable holder.....		
10	2				9959-0820-16	Schraube	Screw.....		
11	1				9739-0831-22	Mutter	Nut.....		
12	1				9747-0831-02	Mutter.....	Lock nut.....		
13	1				1134-6353-01	Fahrpedal.....	Drive pedal.....		
14	2				1134-6313-01	Lager	Bearing.....		
15	2				1134-2700-01	Halter	Bracket.....		
16	2				9959-0820-16	Schraube	Screw.....		
17	2				9739-0831-22	Mutter	Nut.....		
18	1				9997-0835-16	Schraube	Screw.....		
19	1				9739-0831-22	Mutter	Nut.....		
22	1				1134-2766-05	Fahrtregulierdraht.....	Speed control cable.....		
23	2				9570-0001-00	Winkelgelenk	Elbow link.....		
24	2				9739-0531-22	Mutter	Nut.....		
25	2				9747-0531-02	Mutter	Nut.....		
26	1				1134-6317-01	Drahthalter.....	Cable holder.....		
28	2				9959-0620-16	Schraube	Screw.....		
29	2				9739-0631-22	Mutter	Nut.....		
30	1				1134-3395-01	Halterung.....	Attachment.....		
31	2				9959-0820-16	Schraube	Screw.....		
32	2				9739-0831-22	Mutter	Nut.....		
33	1				1134-2021-01	Klemme	Clamp.....		
34	1				1134-5353-01	Bremsstange	Brake rod.....		
35	1				1134-2786-01	Plastikknopf.....	Plastic knob.....		
36	1				1131-1497-01	Feder	Spring.....		
37	1				1134-4002-01	Halterung.....	Brake rod attachment.....		
38	3				9838-9516-12	Schraube	Screw.....		

X

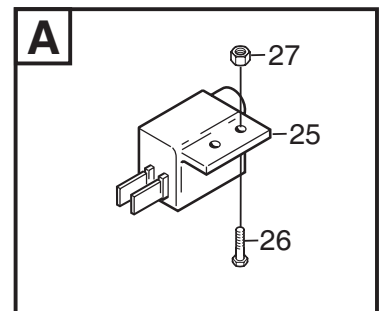
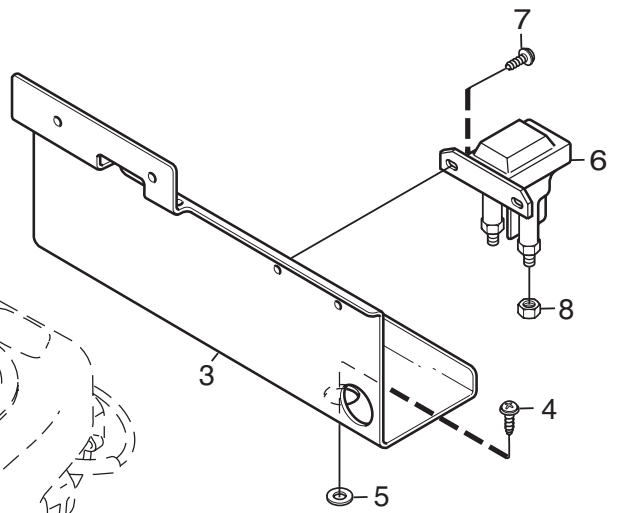
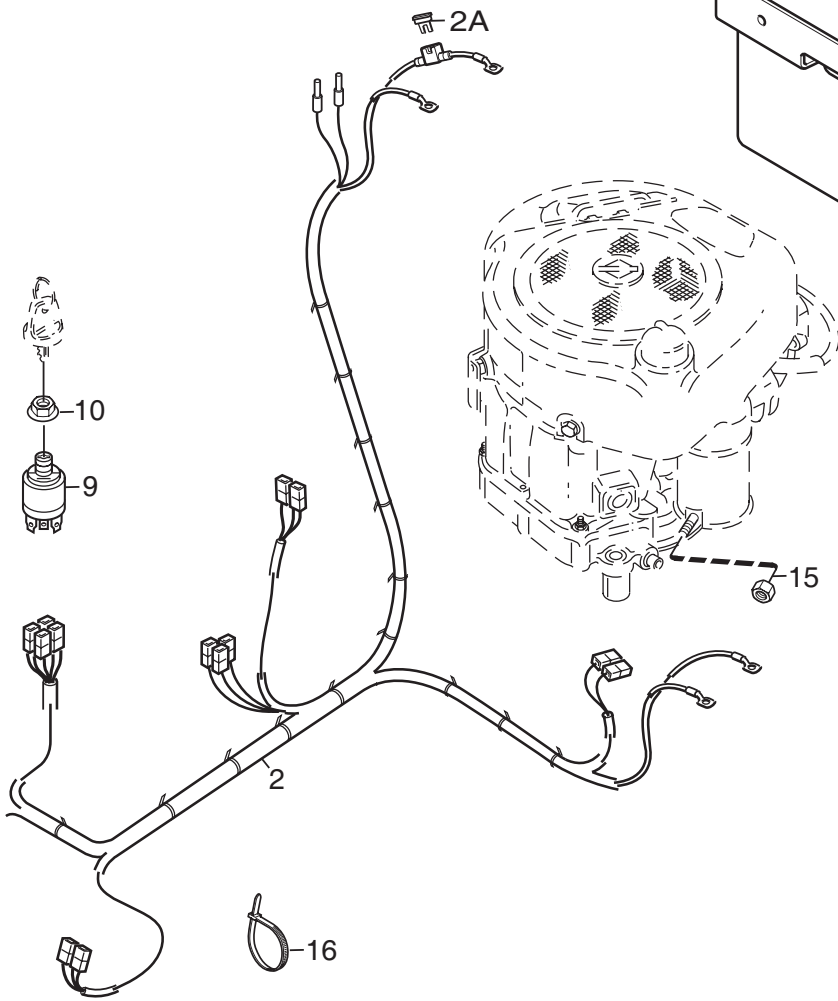
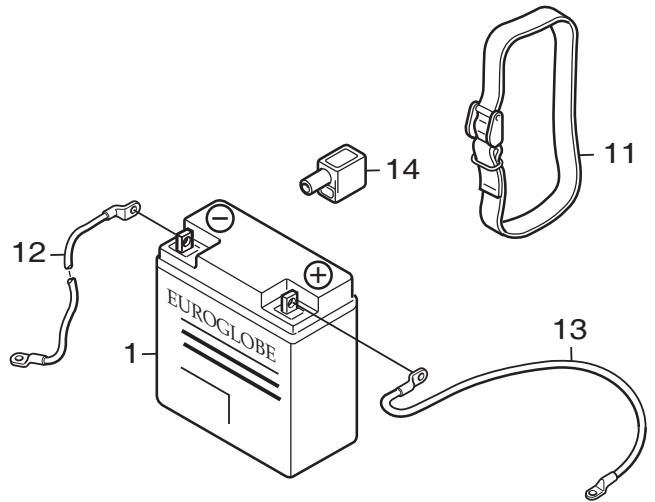
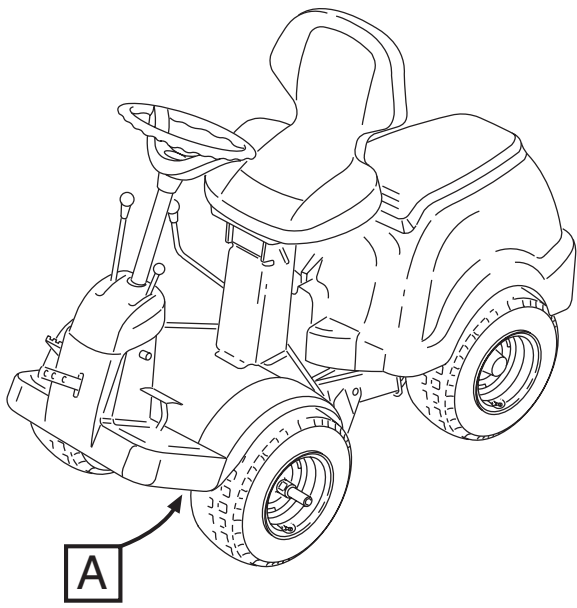

C150A

Ausgabe Issue 2008-31		Bild Nr Picture No C150A		XK 140HD- XK 160HD- XK4 160HD EL. AUSSTATTUNG		XK 140HD- XK 160HD- XK4 160HD EL. EQUIPMENT		Seite Page 98	
Pos. Fig.	Anzahl/Quantity			Artikel Nr. Part No	Bezeichnung	Description	Satz Kit	Anmerkung Notes	
	6102 6103	6104							
1	1	1		1134-4804-01	Batterie	Battery		20A	
2	1	1		1134-5769-01	Kabelbündel	Harness			
2A	1	1		1134-3496-06	• Sicherung	• Fuse			
3	1	1		1134-5343-01	Batteriekonsole	Battery bracket			
4	3	3		9852-8013-16	Schraube	Screw			
5	2	2		9699-0060-02	Scheibe	Flat washer			
6	1	1		1134-3901-01	Magnetschalter	Solenoid			
7	2	2		9852-8013-16	Schraube	Screw			
8	2	2		9794-5131-02	Mutter	Nut			
9	1	1		1134-4093-01	Zündschloß	Ignition switch			
10	1	1		1134-4749-01	Mutter	Nut			
11	1	1		1134-5245-01	Batterieriemen	Battery strap			
12	1	1		1134-2167-01	Kabel	Cable			
13	1	1		1134-0234-02	Batteriekabel (+)	Battery cable (+)			
14	1	1		1134-2310-01	Schutzkappe	Guard cap			
15	1	1		9795-3531-02	Mutter	Nut			
16	15	15		9579-0003-00	Kabelhalter	Cable holder			
25	1	1		1134-3399-02	Schalter	Switch			
26		2		9943-0516-16	Schraube	Screw			
26	2			9997-0520-16	Schraube	Screw			
27	2			9747-0531-02	Mutter	Nut			

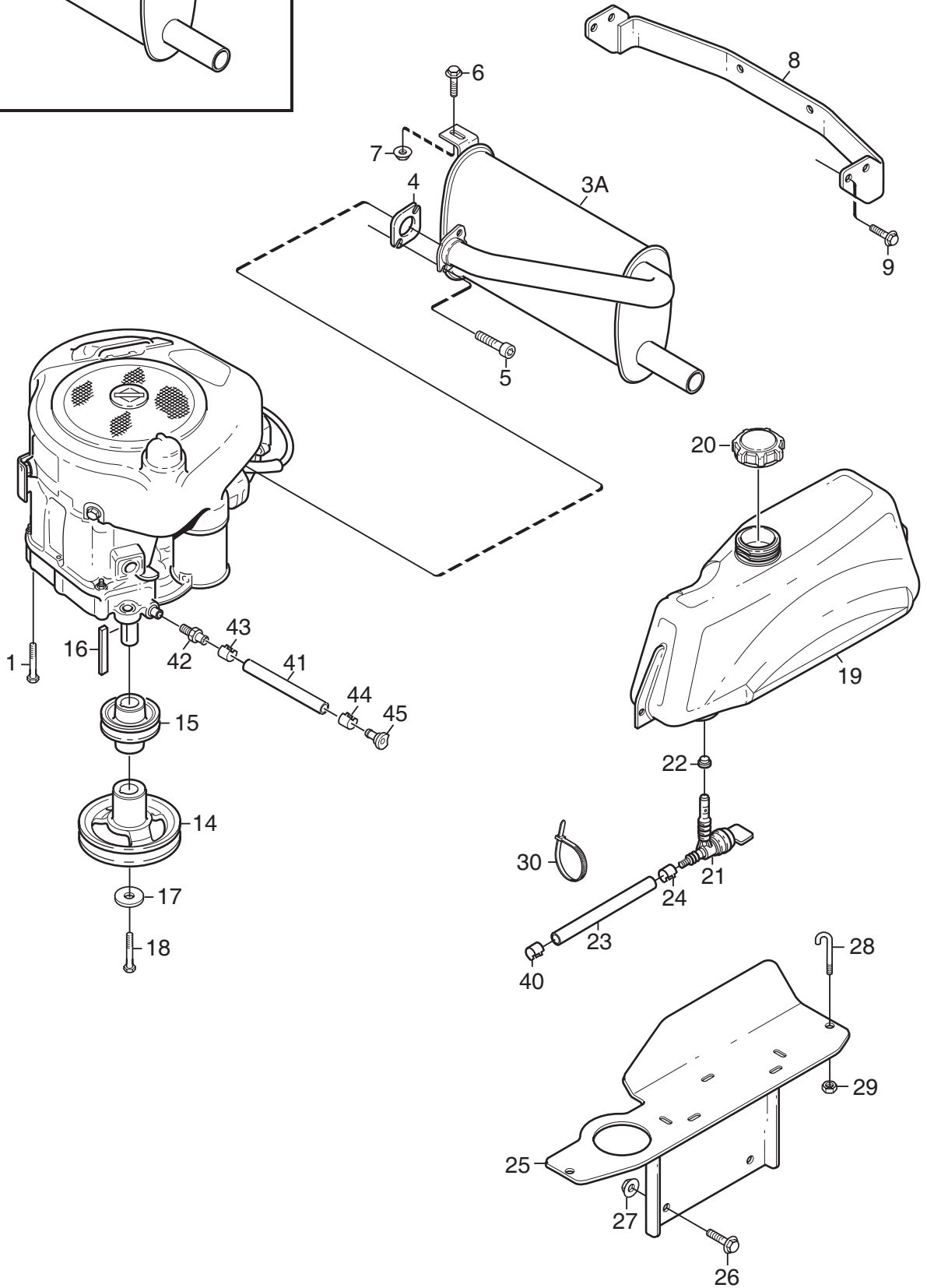
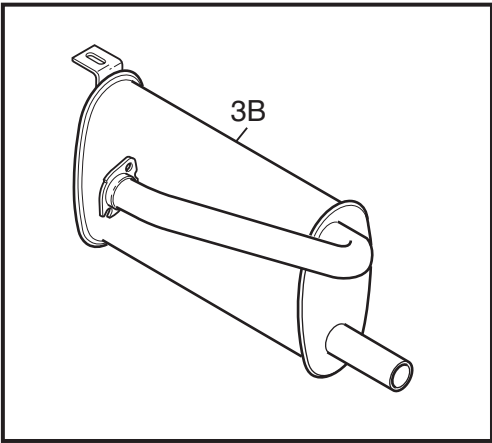

C151A

Ausgabe Issue 2008-31		Bild Nr Picture No C151A		XK 140HD- XK 160HD- XK4 160HD MOTOR		XK 140HD- XK 160HD- XK4 160HD ENGINE		Seite Page 100	
Pos. Fig.	Anzahl/Quantity			Artikel Nr. Part No	Bezeichnung	Description	Satz Kit	Anmerkung Notes	
	6102	6103	6104						
1	4	4	4	9955-3725-16	Schraube	Screw		3/8" UNC x 25 mm	
3A	1			1134-5370-01	Schalldämpfer	Muffler			
3B		1	1	1134-5369-01	Schalldämpfer	Muffler			
4	1	1	1	1134-0433-00	Schalldämpferdichtung.....	Muffler gasket.....			
5	2	2	2	1134-4930-01	Schraube	Screw			
6	1	1	1	9959-0820-16	Schraube	Screw			
7	1	1	1	9739-0831-22	Mutter	Nut			
8	1	1	1	1134-5390-01	Anhängeralterung	Tow bar bracket.....			
9	4	4	4	9945-0816-16	Schraube	Screw			
14	1	1	1	1134-6419-01	Motorriemenscheibe.....	Engine pulley.....			
15	1	1	1	1134-6137-01	Motorriemenscheibe.....	Engine pulley.....			
16	1	1	1	9600-0251-01	Keil	Key	L = 2 1/2"		
17	1	1	1	1134-5017-01	Scheibe.....	Washer			
18	1	1	1	9987-5332-16	Schraube	Screw			
19	1	1	1	1134-6618-01	Kraftstofftank.....	Fuel tank			
20	1	1	1	1134-5532-01	Tankdeckel.....	Fuel tank cap.....			
21	1	1	1	1134-3224-01	Benzinhahn	Fuel shut-off valve			
22	1	1	1	1134-3225-01	Gummibuchse	Grommet.....			
23	1	1		1134-2975-01	Benzinschlauch.....	Fuel hose.....	L = 520 mm L = 350 mm		
23			1	1134-2975-07	Benzinschlauch.....	Fuel hose.....			
24	1	1	1	9578-0023-02	Schlauchklemme	Hose clamp			
25	1	1	1	1134-6627-01	Tankkonsole.....	Fuel tank bracket			
26	2	2	2	9959-0820-16	Schraube	Screw			
27	2	2	2	9739-0831-22	Mutter	Nut			
28	2	2	2	1134-5346-01	Tankbügel	Fuel tank loop.....			
29	2	2	2	9747-0631-02	Mutter	Lock nut			
30	1	1	1	9579-0003-00	Kabelhalter.....	Cable holder			
40	1	1	1	9578-0023-02	Schlauchklemme	Hose clamp			
41	1	1	1	1134-5827-01	Ölablaß kpl.....	Oil drain assy	Pos 42 - 45 incl.		
42	1	1	1	1134-5825-01	• Nippel	• Nipple.....			
43	1	1	1	9578-0023-04	• Schlauchklemme	• Hose clamp			
44	1	1	1	1134-3499-02	• Schlauchklemme	• Hose clamp			
45	1	1	1	1134-5826-01	• Propfen.....	• Plug.....			

X

X

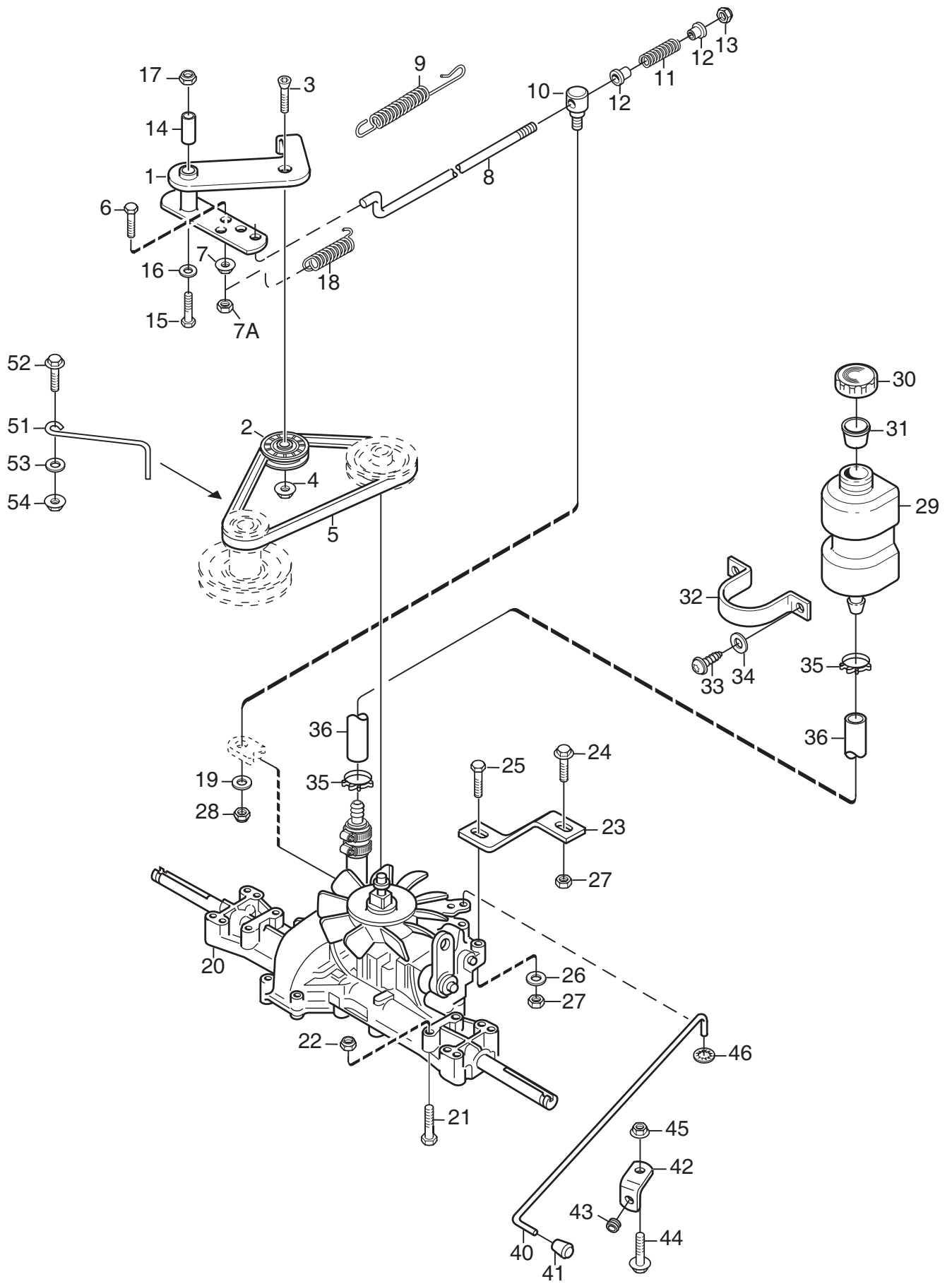

Ausgabe Issue		Bild Nr Picture No		XK 140HD-XK 160HD TRANSMISSION 2WD		XK 140HD-XK 160HD TRANSMISSION 2WD		Seite Page	
2008-31		C153						102	
Pos. Fig.	Anzahl/Quantity				Artikel Nr. Part No	Bezeichnung	Description	Satz Kit	Anmerkung Notes
	6102								
1	1			1134-4000-02	Spannarm	Tension arm			
2	1			1134-3459-01	Spannrolle	Tension roller			
3	1			9924-1035-16	Schraube	Screw			
4	1			9799-1031-02	Mutter	Nut			
5	1			9585-0091-01	Keilriemen	V- belt.....			
6	1			9997-0625-16	Schraube	Screw			
7	1			9739-0631-22	Mutter	Nut			
7A	1			9747-0631-02	Mutter	Lock nut			
8	1			1134-3377-02	Regulierstange.....	Control rod.....			
9	1			4231-0013-00	Feder	Spring			
10	1			1134-4171-01	Gelenkzapfen	Pivot pin.....			
11	1			1134-4183-01	Druckfeder.....	Compression spring.....			
12	2			1134-3456-01	Buchse.....	Bushing.....			
13	1			9747-0631-02	Mutter	Lock nut			
14	1			1134-1565-08	Distanz.....	Spacer.....			
15	1			9997-0870-16	Schraube	Screw			
16	1			9699-0056-02	Scheibe.....	Flat washer.....			
17	1			9747-0831-02	Mutter.....	Lock nut.....			
18	1			1134-6414-01	Feder	Spring			
19	1			9699-0060-02	Scheibe.....	Flat washer.....			
20	1			1134-4848-01	Getriebe kpl	Transaxle assy.....		Kanzaki K46G	
21	4			9960-0860-12	Schraube	Screw			
22	4			9747-0831-02	Mutter	Lock nut			
23	1			1134-3913-01	Strebe	Strut.....			
24	1			9959-0825-16	Schraube	Screw			
25	1			9997-0845-12	Schraube	Screw			
26	1			9699-0090-02	Scheibe.....	Flat washer.....			
27	2			9747-0831-02	Mutter.....	Lock nut.....			
28	1			9747-0631-02	Mutter	Lock nut			
29	1			1134-2765-02	Öltank	Oil tank.....			
30	1			1134-2777-02	Tankdeckel.....	Filler cap			
31	1			1134-3734-01	Entlüftungspropfen.....	Vent plug.....			
32	1			1134-2778-01	Band	Retainer strap			
33	2			9852-8013-16	Schraube	Screw			
34	2			9699-0099-02	Scheibe.....	Washer.....			
35	2			9578-0023-04	Schlauchklemme	Hose clamp			
36	1			1134-2779-07	Schlauch.....	Tube		L = 140 mm	
40	1			1134-4015-01	Zugstange.....	Pull rod			
41	1			1134-4014-01	Plastikknopf.....	Plastic button.....			
42	1			1134-4713-01	Winkel	Bracket.....			
43	1			1134-2790-01	Gummihülse	Rubber grommet.....			
44	1			9959-0820-16	Schraube	Screw			
45	1			9739-0831-22	Mutter	Nut			
46	1			9675-0009-02	Verriegelungsscheibe	Starlock			
51	1			1134-3289-02	Riemenführung.....	Belt guide.....			
52	1			9959-0820-16	Schraube	Screw			
53	1			9699-0056-02	Scheibe.....	Flat washer.....			
54	1			9739-0831-22	Mutter	Nut.....			

X

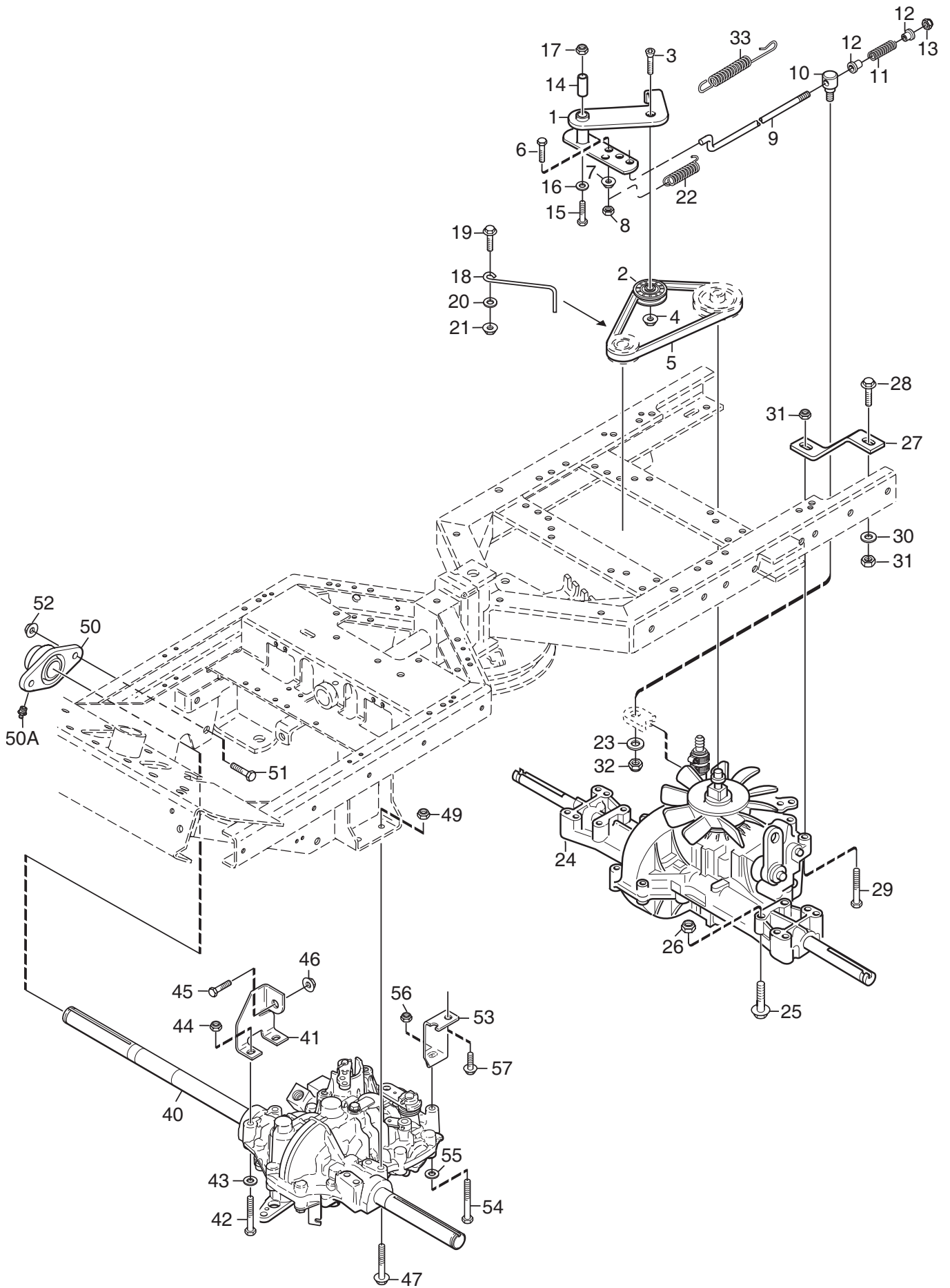

Ausgabe Issue 2008-31		Bild Nr Picture No C154		XK4 160HD TRANSMISSION 4WD (mekanische Teile)		XK4 160HD TRANSMISSION 4WD (mechanical parts)		Seite Page 104	
Pos. Fig.	Anzahl/Quantity				Artikel Nr. Part No	Bezeichnung	Description	Satz Kit	Anmerkung Notes
	6104								
1	1				1134-4000-02	Spannarm	Tension arm		
2	1				1134-3459-01	Spannrolle	Tension roller		
3	1				9924-1035-16	Schraube	Screw		
4	1				9799-1031-02	Mutter	Nut		
5	1				9585-0091-01	Keilriemen	V- belt.....		
6	1				9997-0625-16	Schraube	Screw		
7	1				9739-0631-22	Mutter	Nut		
8	1				9747-0631-02	Mutter	Lock nut		
9	1				1134-3377-02	Regulierstange.....	Control rod.....		
10	1				1134-4171-01	Gelenkzapfen	Pivot pin		
11	1				1134-4183-01	Druckfeder.....	Compression spring.....		
12	2				1134-3456-01	Buchse.....	Bushing.....		
13	1				9747-0631-02	Mutter	Lock nut		
14	1				1134-1565-08	Distanz.....	Spacer		
15	1				9997-0870-16	Schraube	Screw		
16	1				9699-0056-02	Scheibe.....	Flat washer.....		
17	1				9747-0831-02	Mutter.....	Lock nut		
18	1				1134-3289-02	Riemenführung.....	Belt guide		
19	1				9959-0820-16	Schraube	Screw		
20	1				9699-0056-02	Scheibe.....	Flat washer.....		
21	1				9739-0831-22	Mutter	Nut		
22	1				1134-6414-01	Feder	Spring		
23	1				9699-0060-02	Scheibe.....	Flat washer.....		
24	1				1134-6394-01	Getriebe kpl	Transaxle assy.....		Kanzaki K574G
25	4				9960-0860-12	Schraube	Screw		
26	4				9747-0831-02	Mutter.....	Lock nut		
27	1				1134-3913-01	Strebe.....	Strut		
28	1				9959-0825-16	Schraube	Screw		
29	1				9997-0845-12	Schraube	Screw		
30	1				9699-0090-02	Scheibe.....	Flat washer.....		
31	2				9747-0831-02	Mutter.....	Lock nut		
32	1				9747-0631-02	Mutter	Lock nut		
33	1				4231-0013-00	Feder	Spring		
40	1				1134-6029-01	Motorachse- vorne.....	Transaxle- front		Kanzaki KTM 10M
41	1				1134-5650-01	Getriebehalter	Transaxle bracket		
42	2				9997-0860-16	Schraube	Screw		
43	2				9699-0090-02	Scheibe.....	Flat washer.....		
44	2				9747-0831-02	Mutter.....	Lock nut		
45	1				9959-1025-16	Schraube	Screw		
46	1				9731-1031-22	Mutter.....	Nut		
47	2				9960-0860-12	Schraube	Screw		
49	2				9747-0831-02	Mutter.....	Lock nut		
50	1				1134-5703-01	Flanschlager	Flange bearing.....		
50A	1				9501-0500-00	• Schmiernippel.....	• Grease joint.....		
51	2				9997-1040-16	Schraube	Screw		
52	2				9731-1031-22	Mutter.....	Nut		
53	1				1134-5670-01	Strebe.....	Strut		
54	1				9997-0880-16	Schraube	Screw		
55	1				9699-0090-02	Scheibe.....	Flat washer.....		
56	1				9747-0831-02	Mutter.....	Lock nut		
57	2				9945-0816-16	Schraube	Screw		

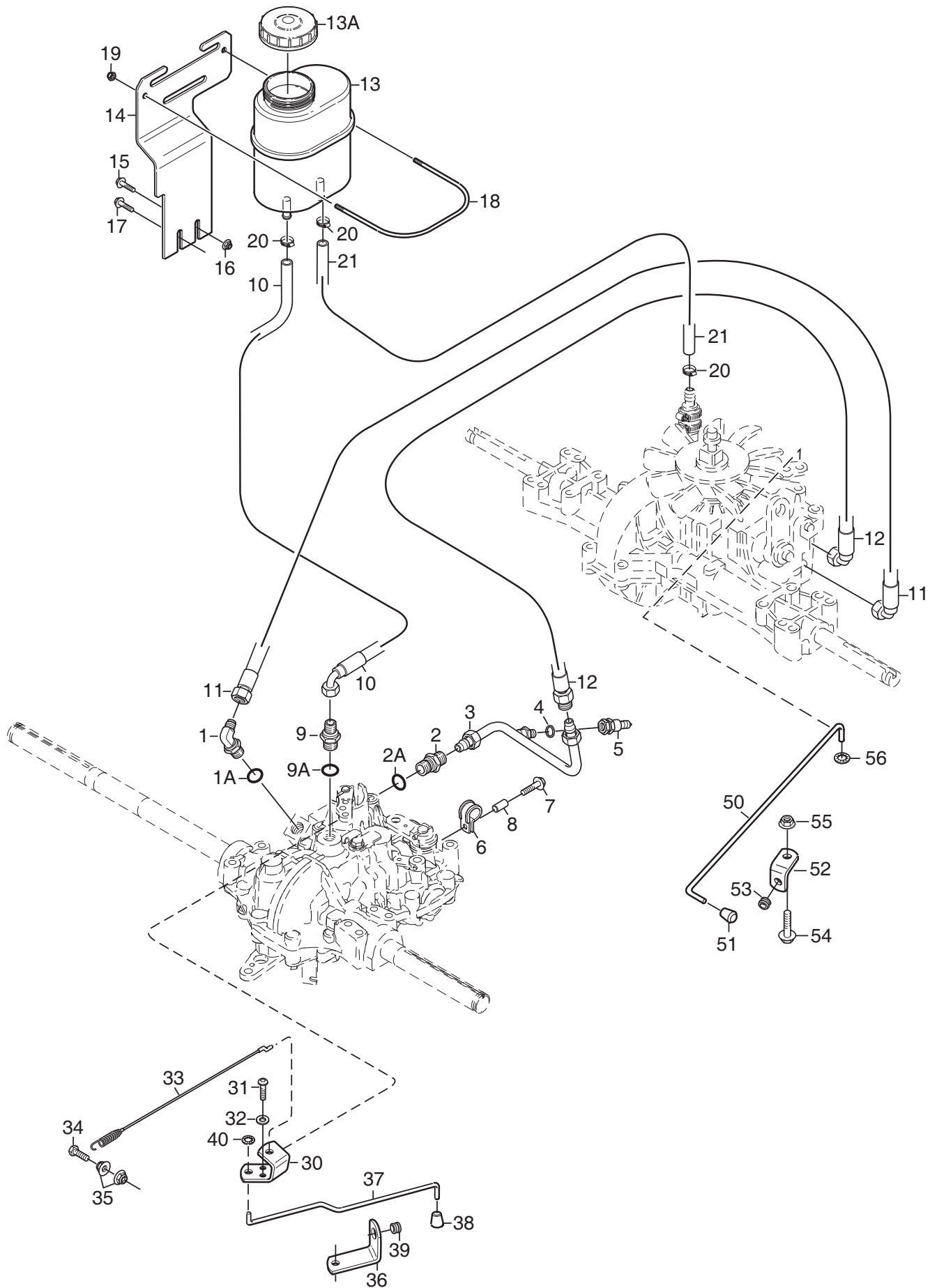

Ausgabe Issue 2008-31		Bild Nr Picture No C155		XK4 160HD TRANSMISSION 4WD (hydraulische Teile)		XK4 160HD TRANSMISSION 4WD (hydraulic parts)		Seite Page 106	
Pos. Fig.	Anzahl/Quantity				Artikel Nr. Part No	Bezeichnung	Description	Satz Kit	Anmerkung Notes
	6104								
1	1				1134-6044-01 Winkeladapter.....	Angle coupling			3/4" x 9/16"
1A	1				9404-0029-01 • O-ring.....	• O-ring			
2	1				1134-5875-01 Hydraulikkupplung.....	Hydraulic coupling			3/4"
2A	1				9404-0029-01 • O-ring.....	• O-ring			
3	1				1134-6039-01 Hydraulrohr	Hydraulic pipe			
4	1				1134-4948-01 Dichtungsscheibe	Seal washer.....			1/4"
5	1				1134-6042-01 Schnellkupplung	Quick coupling-male.....			
6	1				9578-0028-01 Rohrklemme.....	Tube clamp.....			
7	1				9959-0825-16 Schraube	Screw			
8	1				1134-1565-09 Distanz.....	Spacer.....			
9	1				1134-5809-01 Hydraulikkupplung.....	Hydraulic coupling			3/4" x 9/16"
9A	1				9404-0029-01 • O-ring.....	• O-ring			
10	1				1134-5758-01 Hydraulschlauch	Hydraulic tube.....			
11	1				1134-6048-01 Hydraulschlauch	Hydraulic tube.....			
12	1				1134-6043-01 Hydraulschlauch	Hydraulic tube.....			
13	1				1134-6011-01 Hydraulöltank	Hydraulic oil tank			
13A	1				1134-5965-01 • Tankdeckel	• Tank cap			
14	1				1134-6009-01 Tankkonsole.....	Tank bracket.....			
15	1				9959-0820-16 Schraube	Screw			
16	1				9739-0831-22 Mutter	Nut			
17	1				9945-0816-16 Schraube	Screw			
18	1				1134-6030-01 Tankbügel	Tank loop			
19	2				9747-0631-02 Mutter	Lock nut			
20	3				9578-0023-04 Schlauchklemme	Hose clamp			
21	1				1134-2779-08 Schlauch.....	Tube			L = 165 mm
30	1				1134-6162-01 Halterung	Bracket.....			
31	2				9939-0612-16 Schraube	Screw			
32	2				9699-0025-02 Scheibe.....	Washer.....			
33	1				1134-6163-01 Draht	Cable			
34	1				9997-0835-12 Schraube	Screw			
35	2				9739-0831-22 Mutter	Nut			
36	1				1134-6084-01 Konsole	Control bracket			
37	1				1134-6083-01 Regulierstange.....	Control rod.....			
38	1				1134-4014-01 Plastikknopf.....	Plastic button			
39	1				1134-2790-01 Gummihülse	Rubber grommet.....			
40	1				9675-0009-02 Verriegelungsscheibe	Starlock			
50	1				1134-4015-01 Zugstange.....	Pull rod			
51	1				1134-4014-01 Plastikknopf.....	Plastic button			
52	1				1134-4713-01 Winkel	Bracket.....			
53	1				1134-2790-01 Gummihülse	Rubber grommet.....			
54	1				9959-0820-16 Schraube	Screw			
55	1				9739-0831-22 Mutter	Nut			
56	1				9675-0009-02 Verriegelungsscheibe	Starlock			

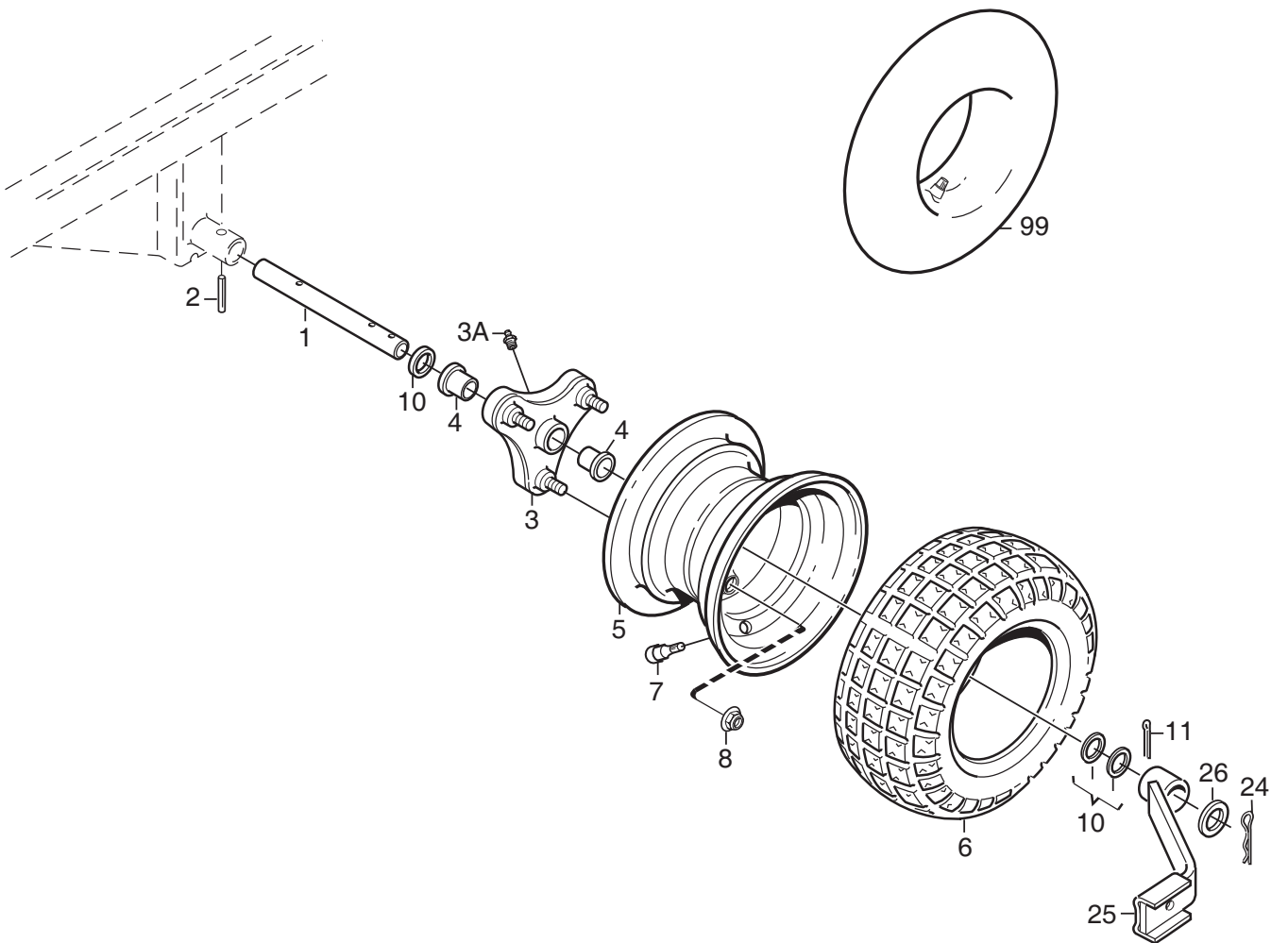
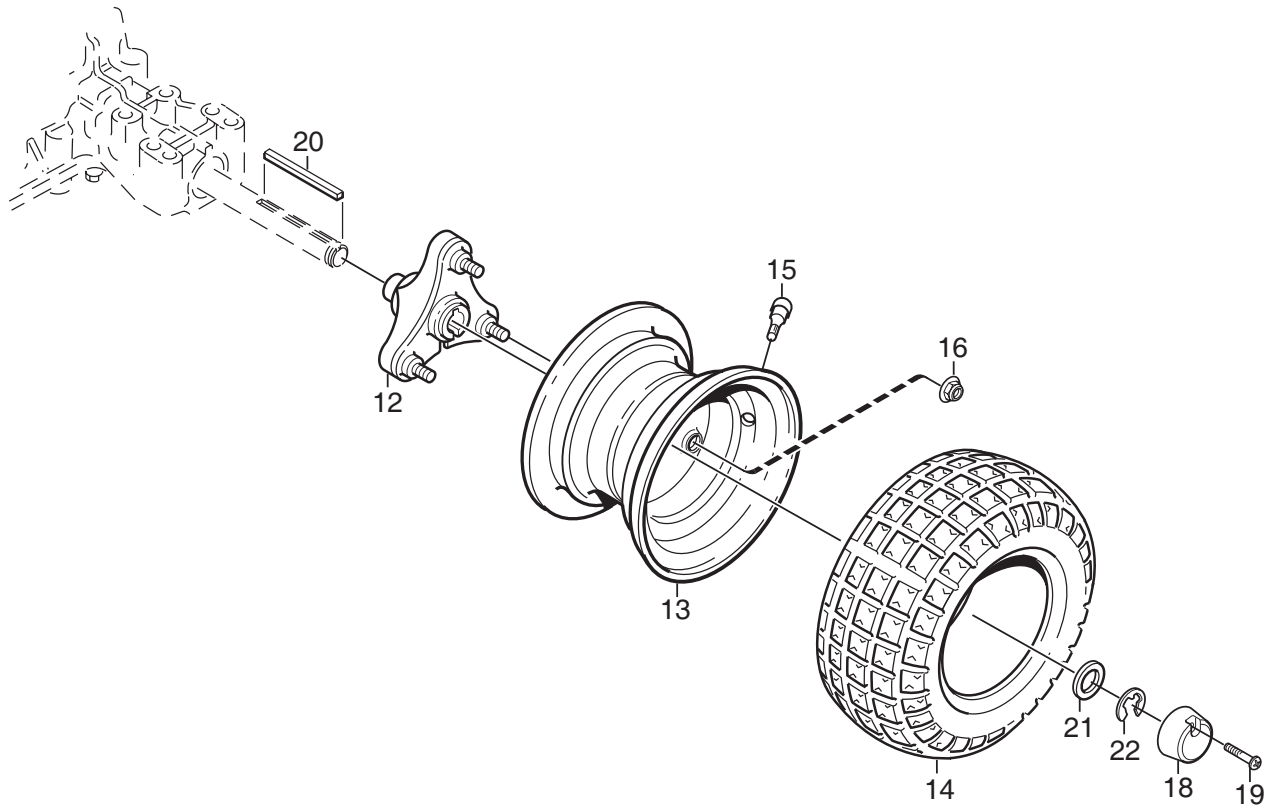

Ausgabe Issue		Bild Nr Picture No		XK 140HD- XK 160HD RÄDER 2WD		XK 140HD- XK 160HD WHEELS 2WD		Seite Page	
2008- 31		C156						108	
Pos. Fig.	Anzahl/Quantity			Artikel Nr. Part No	Bezeichnung	Description	Satz Kit	Anmerkung Notes	
	6102	6103							
1	2	2		1134- 0075- 01	Vorderachse	Front axle			
2	2	2		9595- 0258- 00	Spannstift	Locating pin			
3	2	2		1134- 4844- 05	Radnabe Kpl	Wheel hub assy			
3A	1	1		9501- 0500- 00	• Schmiernippel.....	• Grease joint.....			
4	2	2		1134- 1319- 01	• Lagerbuchse.....	• Bearing bush.....			
5		2		1134- 4558- 01	Felge.....	Rim			
5	2			1134- 5255- 01	Felge.....	Rim			
6		2		9545- 0116- 00	Reifen	Tyre		16 x 7.50 - 8	
6	2			9545- 0126- 01	Reifen	Tyre		16 x 6.00 - 8	
7	2	2		9545- 0500- 00	Ventil	Valve			
8	6	6		9731- 1031- 22	Mutter.....	Nut			
10	8	8		1134- 0341- 01	Scheibe.....	Washer.....			
11	2	2		9599- 0080- 02	Splint.....	Cotter pin			
12	2	2		1134- 4844- 02	Radnabe	Wheel hub			
13		2		1134- 4558- 01	Felge.....	Rim			
13	2			1134- 5255- 01	Felge.....	Rim			
14		2		9545- 0116- 00	Reifen	Tyre		16 x 7.50 - 8	
14	2			9545- 0126- 01	Reifen	Tyre		16 x 6.00 - 8	
15	2	2		9545- 0500- 00	Ventil	Valve			
16	6	6		9731- 1031- 22	Mutter.....	Nut			
18	2	2		1134- 4796- 01	Nabenkapsel.....	Hub cap.....			
19	2	2		9947- 0540- 19	Schraube	Screw.....			
20	2	2		1134- 2471- 01	Keil	Key		L = 58 mm	
21	2	2		9699- 0042- 02	Scheibe.....	Flat washer.....			
22	2	2		9653- 0001- 04	Schließring	Lock ring			
24	2	2		9598- 0003- 02	Schließnadel	Spring pin			
25	2	2		1134- 3710- 01	Geräthalter.....	Tool attachment			
26	2	2		9699- 0042- 02	Scheibe.....	Flat washer.....			
99				9545- 0203- 00	Innenschlauch	Inner tube		Only as spare part	

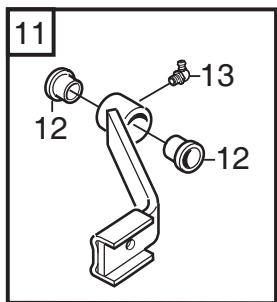
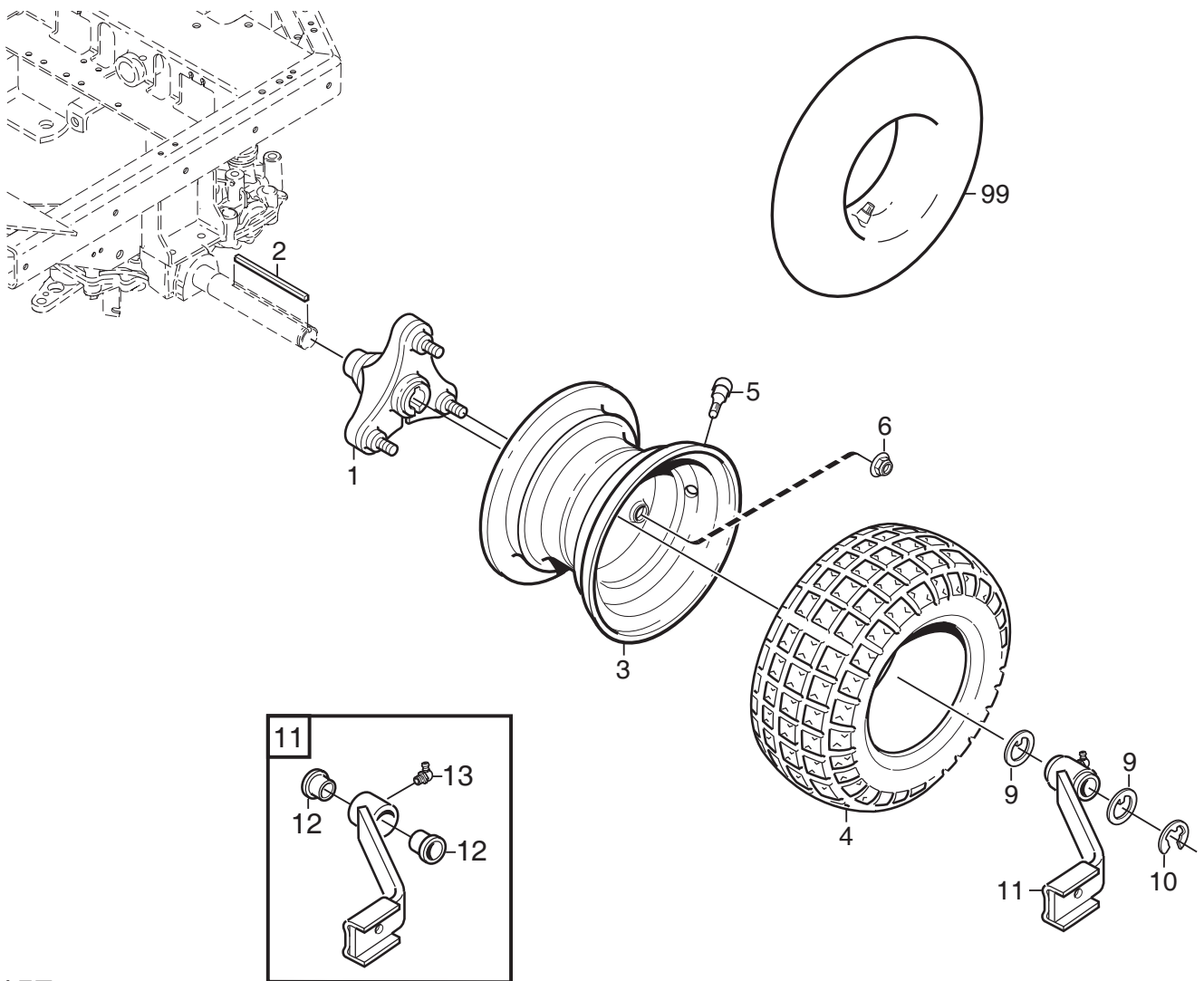
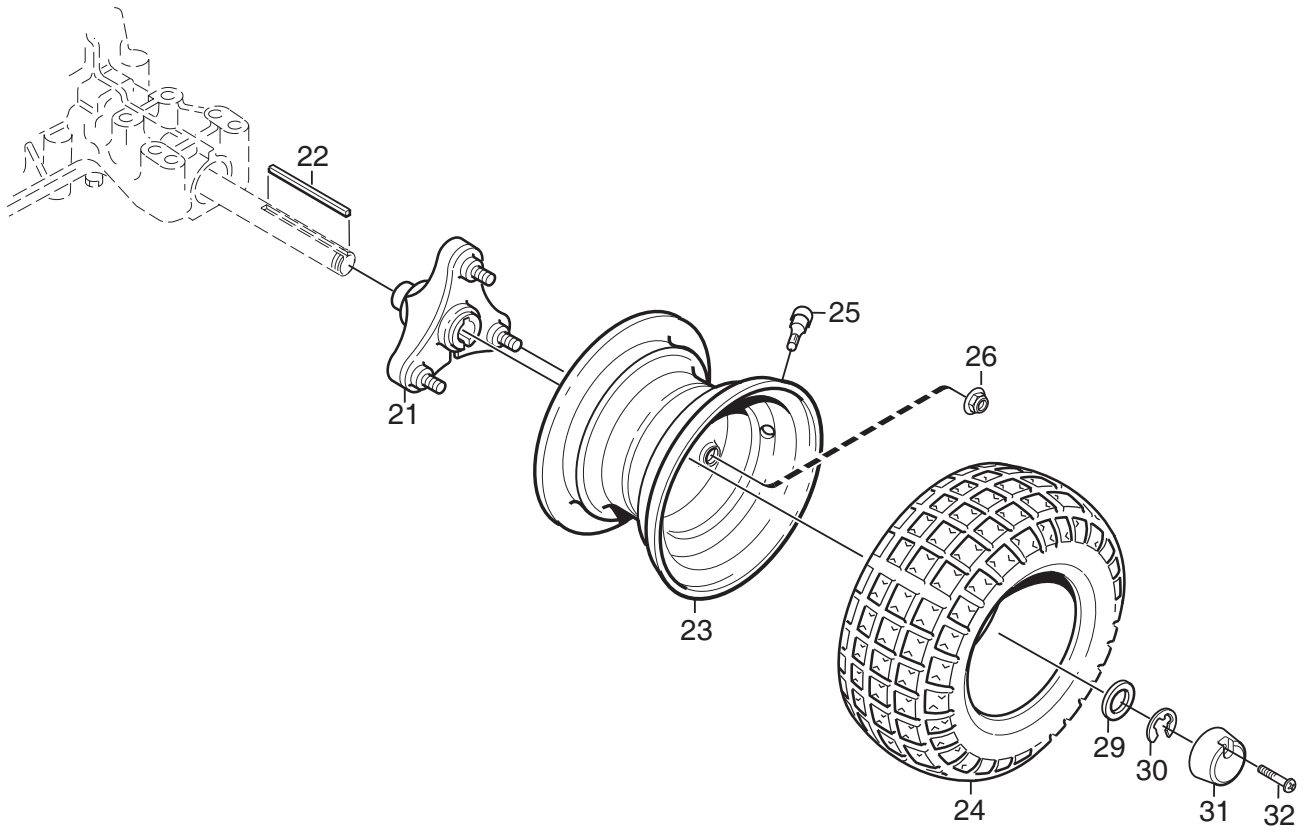

Ausgabe Issue 2008-31		Bild Nr Picture No C157		XK4 160HD RÄDER 4WD		XK4 160HD WHEELS 4WD		Seite Page 110		
Pos. Fig.	Anzahl/Quantity				Artikel Nr. Part No	Bezeichnung	Description	Satz Kit	Anmerkung Notes	
	6104									
1	2				1134-4844-03 Radnabe	Wheel hub			16 x 7.50 - 8	
2	2				1134-3383-02 Keil	Key				
3	2				1134-4558-01 Felge	Rim				
4	2				9545-0116-00 Reifen	Tyre				
5	2				9545-0500-00 Ventil	Valve				
6	6				9731-1031-22 Mutter	Nut				
9	4				1134-5797-01 Scheibe	Washer				
10	2				9653-0002-04 Schließring	Lock ring				
11	2				1134-5886-01 Geräthalter Kpl.	Tool attachment assy				
12	2				1134-5686-01 • Lagerbuchse	• Bearing bush				
13	1				9501-0502-00 • Schmiernippel	• Grease joint				
21	2				1134-4844-02 Radnabe	Wheel hub				
22	2				1134-2471-01 Keil	Key				
23	2				1134-4558-01 Felge	Rim				
24	2				9545-0116-00 Reifen	Tyre		16 x 7.50 - 8		
25	2				9545-0500-00 Ventil	Valve				
26	6				9731-1031-22 Mutter	Nut				
29	2				9699-0042-02 Scheibe	Flat washer				
30	2				9653-0001-04 Schließring	Lock ring				
31	2				1134-4796-01 Nabenkapsel	Hub cap				
32	2				9947-0540-19 Schraube	Screw				
99					9545-0203-00 Innenschlauch	Inner tube				
										Only as spare part

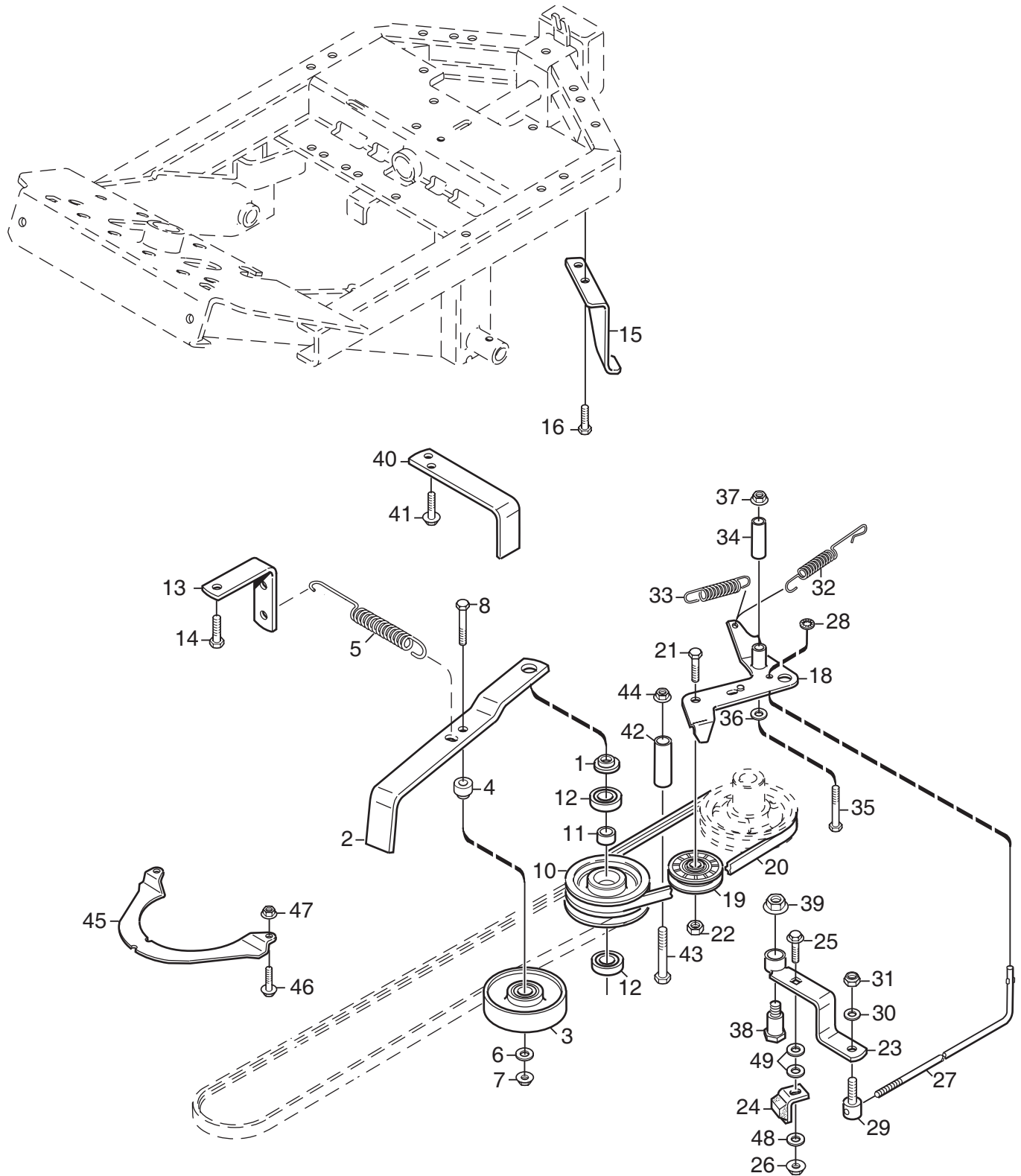

Ausgabe Issue 2008-31		Bild Nr Picture No C158		XK 140HD- XK 160HD NEBENANTRIEB 2WD		XK 140HD- XK 160HD POWER TAKE- OFF 2WD		Seite Page 112	
Pos. Fig.	Anzahl/Quantity				Artikel Nr. Part No	Bezeichnung	Description	Satz Kit	Anmerkung Notes
	6102								
1	1				1134-5548-01	Distanz.....	Spacer.....		
2	1				1134-5109-01	Spannradarm.....	Tension wheel arm.....		
3	1				1134-1770-01	Spannrolle.....	Tension roller.....		
4	1				1134-1888-04	Distanz.....	Spacer.....		
5	1				1134-5111-01	Feder.....	Spring.....		
6	1				9699-0056-02	Scheibe.....	Flat washer.....		
7	1				9739-0831-22	Mutter.....	Nut.....		
8	1				9997-0855-12	Schraube.....	Screw.....		
10	1				1134-1769-03	Riemenscheibe Kpl.....	Centre pulley assy.....		
11	1				1134-0051-09	• Distanz.....	• Spacer.....		
12	2				9549-0019-00	• Kugellager.....	• Ball bearing.....		
13	1				1134-5112-01	Federhalterung.....	Spring attachment.....		
14	2				9945-0816-16	Schraube.....	Screw.....		
15	1				1134-5110-01	Haken.....	Hook.....		
16	2				9893-0616-16	Schraube.....	Screw.....		
18	1				1134-2018-02	Spannarm.....	Tension arm.....		
19	1				1134-2989-02	Spannrolle- grau.....	Tension roller- grey.....		
20	1				9585-0129-01	Keilriemen.....	V- belt.....		
21	1				9997-1030-16	Schraube.....	Screw.....		
22	1				9799-1031-02	Mutter.....	Nut.....		
23	1				1134-4111-01	Bremsarm.....	Brake arm.....		
24	1				1134-4164-03	Bremsklotz.....	Brake pad.....		
25	1				9897-0825-16	Schraube.....	Screw.....		
26	1				9747-0831-02	Mutter.....	Lock nut.....		
27	1				1134-4162-01	Bremsstange.....	Brake rod.....		
28	1				9675-0008-02	Verriegelungsscheibe.....	Locking washer.....		
29	1				1134-4170-01	Nippel.....	Nipple.....		
30	1				9699-0025-02	Scheibe.....	Washer.....		
31	1				9747-0631-02	Mutter.....	Lock nut.....		
32	1				4231-0013-00	Feder.....	Spring.....		
33	1				1134-4231-01	Zugfeder.....	Spring.....		
34	1				1134-1565-10	Distanz.....	Spacer.....		
35	1				9997-0860-16	Schraube.....	Screw.....		
36	1				9699-0056-02	Scheibe.....	Flat washer.....		
37	1				9739-0831-22	Mutter.....	Nut.....		
38	1				1134-4163-01	Ansatzschraube.....	Shoulder bolt.....		
39	1				9731-1031-22	Mutter.....	Nut.....		
40	1				1134-3958-01	Riemenführung.....	Belt guide.....		
41	2				9893-0616-16	Schraube.....	Screw.....		
42	1				1134-0041-03	Hülse.....	Collar.....		
43	1				9997-1070-12	Schraube.....	Screw.....		
44	1				9739-1031-22	Mutter.....	Nut.....		
45	1				1134-3654-01	Fingerschutz.....	Finger guard.....		
46	2				9959-0612-16	Schraube.....	Screw.....		
47	2				9739-0631-22	Mutter.....	Nut.....		
48	1				9699-0090-02	Scheibe.....	Flat washer.....		
49	2				9699-0035-02	Scheibe.....	Flat washer.....		

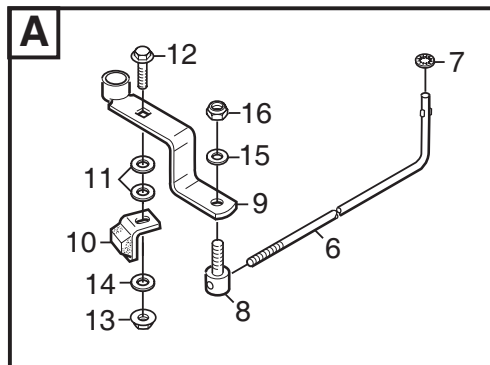
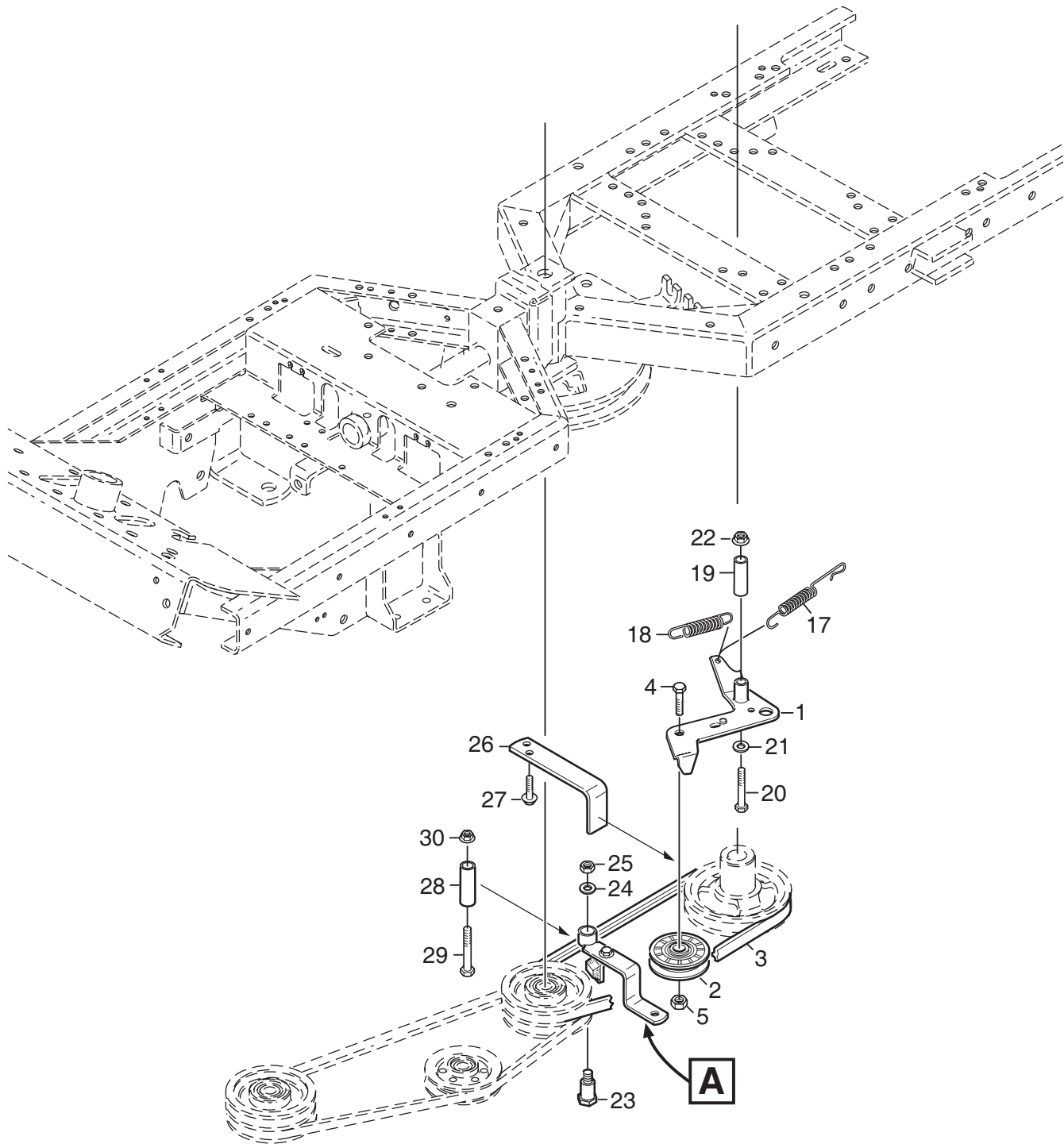

Ausgabe Issue 2008-31		Bild Nr Picture No C159		XK4 160HD NEBENANTRIEB 4WD		XK4 160HD POWER TAKE- OFF 4WD		Seite Page 114	
Pos. Fig.	Anzahl/Quantity				Artikel Nr. Part No	Bezeichnung	Description	Satz Kit	Anmerkung Notes
	6104								
1	1				1134-2018-02	Spannarm	Tension arm		
2	1				1134-2989-02	Spannrolle- grau	Tension roller- grey		
3	1				9585-0129-01	Keilriemen	V- belt		
4	1				9997-1030-16	Schraube	Screw		
5	1				9799-1031-02	Mutter	Nut		
6	1				1134-4162-01	Bremsstange	Brake rod		
7	1				9675-0008-02	Verriegelungsscheibe	Locking washer		
8	1				1134-4170-01	Nippel	Nipple		
9	1				1134-4111-01	Bremsarm	Brake arm		
10	1				1134-4164-03	Bremsklotz	Brake pad		
11	2				9699-0035-02	Scheibe	Flat washer		
12	1				9897-0825-16	Schraube	Screw		
13	1				9747-0831-02	Mutter	Lock nut		
14	1				9699-0090-02	Scheibe	Flat washer		
15	1				9699-0025-02	Scheibe	Washer		
16	1				9747-0631-02	Mutter	Lock nut		
17	1				4231-0013-00	Feder	Spring		
18	1				1134-4231-01	Zugfeder	Spring		
19	1				1134-1565-10	Distanz	Spacer		
20	1				9997-0860-16	Schraube	Screw		
21	1				9699-0056-02	Scheibe	Flat washer		
22	1				9739-0831-22	Mutter	Nut		
23	1				1134-4163-01	Ansatzschraube	Shoulder bolt		
24	1				9699-0035-02	Scheibe	Flat washer		
25	1				9739-1031-22	Mutter	Nut		
26	1				1134-3958-01	Riemenführung	Belt guide		
27	2				9893-0616-16	Schraube	Screw		
28	1				1134-0041-03	Hülse	Collar		
29	1				9997-1070-12	Schraube	Screw		
30	1				9739-1031-22	Mutter	Nut		

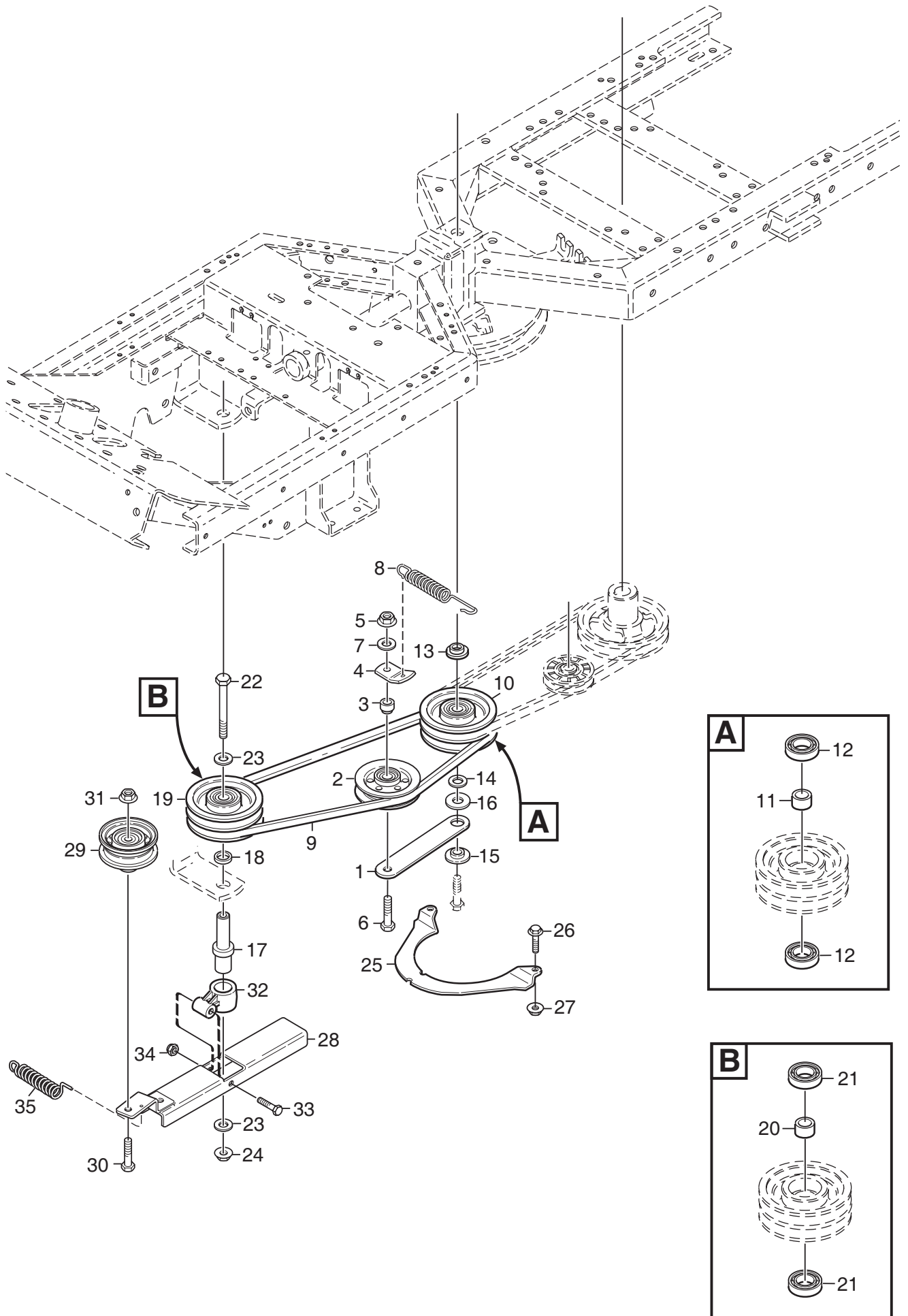

Ausgabe Issue 2008-31		Bild Nr Picture No C160		XK4 160HD NEBENANTRIEB 4WD		XK4 160HD POWER TAKE- OFF 4WD		Seite Page 116	
Pos. Fig.	Anzahl/Quantity				Artikel Nr. Part No	Bezeichnung	Description	Satz Kit	Anmerkung Notes
	6104								
1	1				1134-1730-01	Spannradarm.....	Tension wheel arm.....		
2	1				1134-3663-01	Spannrolle.....	Tension wheel.....		
3	1				1134-1888-05	Distanz.....	Spacer.....		
4	1				1134-1893-01	Federhalterung.....	Spring attachment.....		
5	1				9739-1031-22	Mutter.....	Nut.....		
6	1				9997-1060-12	Schraube.....	Screw.....		
7	1				9699-0035-02	Scheibe.....	Flat washer.....		
8	1				1134-5713-01	Zugfeder.....	Spring.....		
9	1				9585-0148-01	Keilriemen.....	V-belt.....		
10	1				1134-1769-03	Riemenscheibe Kpl.....	Centre pulley assy.....		
11	1				1134-0051-09	• Distanz.....	• Spacer.....		
12	2				9549-0019-00	• Kugellager.....	• Ball bearing.....		
13	1				1134-5548-01	Distanz.....	Spacer.....		
14	1				9699-0035-02	Scheibe.....	Flat washer.....		
15	1				1134-0222-00	Spannradscheibe.....	Washer.....		
16	1				9699-0109-02	Scheibe.....	Flat washer.....		
17	1				1134-5663-01	Achse.....	Shaft.....		
18	1				1134-0052-00	Lagerdistanz.....	Bearing spacer.....		
19	1				1134-1769-03	Riemenscheibe Kpl.....	Centre pulley assy.....		
20	1				1134-0051-09	• Distanz.....	• Spacer.....		
21	2				9549-0019-00	• Kugellager.....	• Ball bearing.....		
22	1				9997-1011-06	Schraube.....	Screw.....		
23	2				9699-0030-02	Scheibe.....	Flat washer.....		
24	1				9739-1031-22	Mutter.....	Nut.....		
25	1				1134-3654-01	Fingerschutz.....	Finger guard.....		
26	2				9959-0612-16	Schraube.....	Screw.....		
27	2				9739-0631-22	Mutter.....	Nut.....		
28	1				1134-5660-01	Spannarm.....	Tension arm.....		
29	1				1134-5823-01	Spannrolle.....	Tension roller.....		
30	1				9997-1050-16	Schraube.....	Screw.....		
31	1				9739-1031-22	Mutter.....	Nut.....		
32	1				1134-6314-01	Halterung.....	Attachment.....		
33	1				9997-0645-12	Schraube.....	Screw.....		
34	1				9747-0631-02	Mutter.....	Lock nut.....		
35	1				1134-5824-01	Feder.....	Spring.....		